



Glass & Glazing Federation

CI/SfB

Ro

Summer 2011

Issue 3



A Guide to Best Practice in the Specification and Use of Fire-Resistant Glazed Systems

Introduction

Table of Contents

Introduction

Introduction by Chairman	7
Terms used in this Best Practice Guide	8
A quick reference guide to the key factors to be considered in specifying fire-resistant glazing and appointing a glazing contractor	10
Reference to principle Building Regulations	
England and Wales	11
Scotland	11
Northern Ireland	12
Codes of Practice and Standards	12
Key points of Best Practice	13

Section 1 - Principles

Design flexibility	16
Planning	16
New build	17
Building refurbishment	17
Upgrade or replacement	17
Fire-resistant glazing systems	18
Responsibilities	18
Glossary of terms	20
Applications	22
Applicable standards for fire-resistance	23
Regulations covering fire safety	23
Classification of fire-resistance in UK building regulations	23
Approved Document B (England and Wales)	24
Regulatory Reform (Fire Safety) Order 2005	29
Building Regulation 38 (formerly 16B)	30
Classification of fire-resistance to harmonised European Norms	31
Property protection - Principles	32
Reaction in the Event of Fire	33

Section 2 - Evidence of Fire Performance

Introduction	35
Test reports	36
Assessment reports	36
Third-party certificates	37
CE marking	
EC Certificate of conformity	38
Classification report	38
EC Declaration of conformity	38
Field of application	38
CE marking and harmonised product standards	39
Alternative routes to demonstrate fire-resistance performance	40

Section 3—Fire-Resistant Glass

Glass types	42
Performance in the event of fire	44

Introduction

Table of Contents cont.

Fire-resistant insulating glass units	46
Horizontal and sloped glazing systems	46
Decorative treatments on glass	47
Combining other performance requirements with fire-resisting glazing	47
Section 4 - Fire-Resistant Glazing Seals	
Importance of the glazing seal	48
Function of the glazing seal	48
Available forms of seals	48
Intumescent seal types	49
Non-intumescent seal types	50
Seal combinations with different glass types	52
Section 5 - Timber Screens and Doors	
Behaviour of timber in fire	53
Timber density	53
Particular considerations concerning timber fire doors	55
Timber glazing beads	57
Examples of timber bead types and intumescent seals	58
Additional information	60
Bead fixings	60
Setting blocks	60
Integrity and insulation glazing in timber fire-resistant systems	61
Glazing apertures in doors	61
Linings for glazed apertures in timber doors	62
Particular considerations to achieve 60 minute integrity	63
Particular considerations for 60 minute fire doors	64
Fanlights	64
Timber system/trade names	64
Section 6—Metal Systems for Screens and Doors	
Behaviour of metal in fire	65
Metal screens	
Steel	66
Aluminium	66
Composite systems	66
Metal fire doors	67
Beads and fixings	68
Installation	69
Edge cover requirements	69
Key factors affecting performance	
Integrity	69
Insulation	70
Pressure glazed systems	71
Glazing seals for metal framed systems	72
Frames for external applications	72
Curtain walling systems	72
Metal system/trade names	72

Introduction

Table of Contents continued

Section 7 - Frameless (butt-jointed) Systems	
Types of systems	73
Perimeter framing	75
Available systems	75
Butt-jointed system/trade names	75
Section 8 - Fire-Resistant Glass Floors	
Essential requirements	76
Fire performance requirements and testing	76
In service functional requirements	78
Additional functional considerations	78
Systems	79
Connections and gaskets	79
External load-bearing fire-resistant floors	80
Installation	80
Section 9 - Refurbishment and Replacement of Fire-Resistant Glazing	
Refurbishment of fire-resistant glazed doors and screens	
Recommended best practice	81
Glass	82
Timber doors	82
Glazing seals	83
Timber screens	84
Steel doors and screens	83
Upgrading timber doors and screens	83
Protected buildings and historical context	84
Replacement glazing in doors, frames and screens manufactured from materials other than timber or steel	84
Marking of fire-resistant glass	84
Supporting construction	85
Maintenance and aftercare	86
Fire stopping	86
Storage and transport of fire-resistant glass	87
Records and documentation	87
Section 10 - Frequently Asked Questions	88
Appendix A - Membership of FRGG	93
Appendix B - Summary of Impact Safety Requirements	94
Appendix C - Requirements of Glazing Manifestation	96
Appendix D - Contact details of Associated Organisations	97
Disclaimer	99

Introduction

It is almost five years since the best practice guide was first published. The FRGG acknowledged that there was a need for a comprehensive guide to assist in the specification, testing, and use of fire-resistant glazed systems to match the increasing use of specialist glasses within the built environment. Our specific intention was, and still remains, to provide information to the whole construction industry of the need for correctly specified, tested and installed fire-resistant glazed systems. Since its original publication over 5,000 hard copies have been distributed and many visitors to the GGF website have downloaded the FRGG Best Practice Guide.

This third edition has expanded our original document to keep pace with changes in legislation and the constant product development undertaken by our diverse groups' membership. In addition we have added some new sections to reflect these ever changing advancements.

Since the first edition of the guide, we have seen changes in fire safety legislation and standards. These changes include the publication of BS 9999:2008, Code of practice for fire safety in the design, management and use of buildings (this supersedes BS 5588), the revised 2006 edition of Approved Document B (Fire Safety) which references this guide and the introduction of The Regulatory Reform (Fire Safety) Order 2005.

The FRGG has also undertaken the task of producing specific training qualifications for the specification and installation of Fire-Resisting Glazing. These new qualifications (formerly NVQ's) have been developed in line with the new QCF guidelines at levels 2 and 3. These will ensure that an appropriately high level of training is introduced to ensure the correct installation of these complex and intricate, life safety products. The draft modules have been completed and they are currently progressing with Glazing Qualifications Authority (GQA) and will be available during 2011.

The guidance provided within this comprehensive guide has been provided by a broad cross section of individuals and companies engaged in the testing, manufacture, supply and installation of fire-resistant glazed components. Organisations include fire test laboratories, glass manufacturers, seal manufacturers, frame system manufacturers, specialist glass distributors and glazing contractors.

Our membership all endorse the recommendations of the guide and will continue to work and stand by its principles to ensure that high standards are set and maintained in the supply and installation of these life safety products.

Kevin Hulin
Mann McGowan
Chairman FRGG

(The latest information can be found on the GGF's web site www.ggf.org.uk.)

Introduction

The Glass and Glazing Federation (GGF)'s Fire-Resistant Glazing Group (FRGG) is committed to the development and advancement of best practice in the manufacture, testing, specification, application and installation of fire-resistant glazed systems.

Our goal is to work with the wider fire safety community to achieve the optimum fire protection in our buildings. Our target is to develop best practice for fire-resistant glazed systems.

We will seek to meet our objectives by bringing together and making available the latest expert advice of those who work with fire-resistant glazed systems. We will also lead the industry in the development and application of the most appropriate best practice relevant to such systems.

The GGF, as the representative association of the glazing industry, only recognises those within the industry who endorse and subscribe to the policies, aims and objectives of the FRGG by membership of the group.

A necessary condition of FRGG membership is that members follow the principles defined in this document and that they promote, develop and champion the application of best practice in the use of fire-resistant glazing systems with a recognition of their responsibilities in ensuring fitness for purpose in the event of fire.

Glass and Glazing Federation
54 Ayres Street
London
SE1 1EU

Telephone: 0207 939 9100

Facsimile: 0207 939 7458

info@ggf.org.uk

www.ggf.org.uk

Introduction

Note: the following terms are used in this guide:

Responsible Person

(a) in relation to a workplace, the employer, if the workplace is to any extent under his control;

(b) in relation to any premises not falling within paragraph (a)-

i) the person who has control of the premises (as occupier or otherwise) in connection with the carrying on by him of a trade, business or other undertaking (for profit or not); or

ii) the owner, where the person in control of the premises does not have control in connection with the carrying on by that person of a trade, business or other undertaking.)

Where two or more Responsible Persons share this responsibility then they must co-operate, share information and collaborate to ensure that appropriate fire safety measures are in place in the premises (e.g. tenant and landlord, multiple tenancy occupancy, adjacent premises).

Competent Person

This is a person appointed by the Responsible Person to undertake fire safety risk assessments, fire safety management of the premises or work associated with the installation and operation of fire safety systems within the premises under the requirements of the Regulatory Reform (Fire Safety) Order 2005.

The Competent Person may be an employee of the Responsible Person or a contractor with delegated responsibility for the safety of building occupants against fire. If the Competent Person is an employee, the Responsible Person must ensure that appropriate and sufficient training is provided so that the fire safety obligations can be competently discharged. If the Competent Person is a contractor, it is implicit that the contractor must be able to demonstrate appropriate levels of competence, for example by third party accreditation.

Expert Judgment

Expert judgment is a permissible method of demonstrating compliance with the functional requirements of UK regulations, including the assessment of fire-resistance performance of systems, assemblies, and constructions. This can involve, for example, complex engineering evaluations of structures which are not amenable to the application of prescriptive solutions, or relatively less complex evaluations of the expected fire performance of variations on a particular fire-resistant system which has appropriate test evidence.

It is implicit that the expert is a practising professional in the relevant field of fire safety and can demonstrate the appropriate knowledge, qualifications and experience.

It is also implicit that the judgment is related to one or more of the following: known fire behaviour, known material behaviour, test information, appropriate case studies, fire science principles or appropriate engineering-based equations and processes.

Responsibilities

The occurrence and development of fire is essentially unpredictable and uncertain, and its effects can be catastrophic for both life and property. There is therefore a

Introduction

shared duty of care incumbent on all those involved in the specification, testing, supply and installation of fire-resistant glazed systems. It is essential to ensure that the final installed system is fit to protect the building and its occupants against the effects of fire. Critical factors in achieving the intended performance in the event of fire are both the quality and the reliability of product performance and satisfactory workmanship on installation.

Introduction

A quick reference guide to the key factors to be considered in specifying fire-resistant glazing and appointing a glazing contractor

Define the Performance Specification	
<p>Confirm:</p> <ul style="list-style-type: none"> ● Guidance in Approved Document B or BS 9999 ● Alternatives to meet Building Regulations ● Application <ul style="list-style-type: none"> ◆ Internal or External ◆ Façade, screen or door ◆ Vertical, horizontal or inclined ● Frame material (timber, metal or other) <p>Reference:</p> <ul style="list-style-type: none"> ● Section 1 - Basic Principles 	<ul style="list-style-type: none"> ● Bead designs ● Performance class <ul style="list-style-type: none"> ◆ Integrity Only ◆ Integrity with insulation ● Required classification time ● Other performance requirements
Identify an Approved Fire-Resistant Glazing System	
<p>Check:</p> <ul style="list-style-type: none"> ● Test evidence of performance <ul style="list-style-type: none"> ◆ Test report ◆ Assessment report ◆ Certificate from third party scheme <p>Reference:</p> <ul style="list-style-type: none"> ● Section 2—Evidence of Fire Performance 	<p>Confirm:</p> <ul style="list-style-type: none"> ● Details of glazing system to meet the required specification <ul style="list-style-type: none"> ◆ Classification report ◆ Declaration of Conformity ◆ Certificate of Conformity
Confirm Material and Glazing System Specification	
<p>Confirm:</p> <ul style="list-style-type: none"> ● Glass type and name ● Seal type and name ● Frame materials and frame design ● Bead material and design <p>Establish:</p> <ul style="list-style-type: none"> ● Points of detail governing fire performance <p>Reference:</p> <ul style="list-style-type: none"> ● Section 3 - Fire-resistant glass ● Section 4 - Fire-resistant glazing seals ● Section 5 - Timber screens and doors 	<ul style="list-style-type: none"> ● Bead fixings ● Details of assembly ● Details of any finishes and decoration ● Check all relevant drawings <ul style="list-style-type: none"> ● Section 6—Metal systems for screens and doors ● Section 7 Frameless (butt-jointed) systems
Ensure Installation is Correct	
<p>Check with installer:</p> <ul style="list-style-type: none"> ● Third party certification (e.g. FIRAS) ● Glass handling and storage ● Core competencies (NVQ or equivalent trained staff) ● Key skills and knowledge <p>Reference:</p> <ul style="list-style-type: none"> ● Section 8 - Installation 	<ul style="list-style-type: none"> ● Labelling of the glass ● Refurbishment proposals ● Surrounding construction ● Records and documentation
Obtain Answers to Your Key Questions	
<ul style="list-style-type: none"> ● Contact a member of GGR Fire-Resistant Glazing Group <p>Reference:</p> <ul style="list-style-type: none"> ● Appendix A 	

Introduction

Reference to the principle regulations, standards (BS or BS EN) and Codes of Practice

Approved Documents – England and Wales

These are documents created by The Department of Communities and Local Government (CLG), formerly the Office of the Deputy Prime Minister (ODPM) in England and Wales, for the purpose of providing practical guidance on the requirements of the Building Regulations. If a designer fails to follow the recommended guidance given in the Approved Documents then it is for them to prove, to their client or authorities if prosecuted, that an equally effective method or practice has been followed as an alternative. The Approved Documents (AD) particularly relevant to fire-resistant glazing systems and their application are as follows:

- Approved Document B (AD B) – Fire Safety 2006 Edition
- Approved Document E (AD E) – Resistance to passage of sound 2003, amended 2004
- Approved Document K (AD K) – Protection from falling, collision and impact 1998, amended 2000
- Approved Documents L1A, L1B, L2A, L2B (AD L) – Conservation of fuel and power 2010 edition
- Approved Document M (AD M) – Access to and use of buildings 2004
- Approved Document N (AD N) – Glazing – safety in relation to impact, opening and cleaning 1998, amended 2000

Approved Documents – Scotland

The Building (Scotland) Act 2003 gives Ministers the power to make building regulations to:

- Secure the health, safety, welfare and convenience of persons in or about buildings and of others who may be affected by buildings or matters connected with buildings
- Further the conservation of fuel and power
- Further the achievement of sustainable development

Guidance to achieve the required standards set by the Building Regulations in Scotland is given in two sets of documents, *Domestic* and *Non-Domestic* Technical Handbooks.

The sections contained in the Technical Handbooks particularly relevant to fire-resistant glazing systems and their applications are as follows:

- Section 2 – Fire 2010
- Section 4 – Safety 2010
- Section 5 – Noise 2010
- Section 6 – Energy 2010

Introduction

Technical Booklets – Northern Ireland

Technical Booklets are published by the Department of Finance and Personnel in support of some of the technical parts of the regulations. They provide construction methods that, if followed, will be deemed-to-satisfy the requirements of the Building Regulations.

They allow the Department to set certain standards of performance and to provide a degree of predictability and certainty as to what methods and standards of building which, if followed, will satisfy the requirements of building regulations.

These booklets are specifically written for the use of individuals who have a sound knowledge of modern building techniques, terminology and practices.

There is no obligation to follow the methods or comply with the standards set out in the Technical Booklets (or any other named deemed-to-satisfy document). You may adopt any form of construction you wish, however you will have to demonstrate to the satisfaction of district councils that the requirements of the building regulations have been met.

The Technical Booklets particularly relevant to fire-resistant glazing systems and their application are as follows:

- DFP Technical Booklet E: 2005 – Fire Safety
- DFP Technical Booklets F1: 2006 and F2: 2006 – Conservation of fuel and power in dwellings and buildings other than dwellings
- DOE Technical Booklets G: 1990 and G1: 1994 – Sound and Sound in conversions
- DFP Technical Booklet H: 2006 – Stairs, ramps guarding and protection from impact

Relevant Codes of Practice and Standards

BS 5234-2– Partitions (including matching linings) – Specification for performance requirements for strength and robustness including methods of test

BS 6180 – Barriers in and about buildings

BS 6262-4 – Glazing for buildings. Code of practice for safety related to human impact

BS 8000-7 – Workmanship on building sites – Code of Practice for glazing

BS 9999 – Code of practice for fire safety in design, management and use of buildings

BS EN 12600 – Glass in building. Pendulum test, impact test method and classification for flat glass

BS EN 12758 – Glass in buildings. Glazing and airborne sound insulation. Product descriptions and determination of properties

BS EN 1990 – Eurocode: Basis of structural design – consists of 9 separate Eurocodes dealing with all aspects of structural design

Introduction

Key Points of Best Practice

Applications

- Glazed internal and external fire doors
- Interior partitions and compartments
- Roofs, floors and ceilings
- Façade glazing
- Escape and access corridor walls
- Stairways, lobbies and enclosures to protect shafts

Function

Fire-resistant glazing may be used as a barrier for fire separation or compartmentation as part of an integrated fire safety strategy for the building.

Both integrity only and integrity with insulation performance ratings are available

Products span the range of standard test times of 15, 30, 60, 90, 120 and even 180 or 240 minutes according to either BS 476 part 22, BS EN 1364 or BS EN 1634-1, as well as special types to resist the higher intensity petrochemical fire temperature/time test curve (if required).

The Fundamental Golden Rule

Fire-resistant glass must only be used as part of a fire-resistant glazing system – ***which includes the glass, the glazing seals, glazing beads, fixings and frame.***

All the essential components of such a system must be compatible under fire conditions and the performance must be referenced to appropriate and relevant test evidence.

Main factors that can affect performance

- Glass Type
- Maximum glass pane size (by height and width, not just area)
- Glass pane aspect ratio (i.e. height to width)
- Overall screen size and fenestration layout within the screen
- Glazed system components (i.e. frame material, glazing seals and fixings)
- Framing system design for screens and façades
- Type of door, materials and construction
- Fabrication of the glazing aperture in doors (i.e. strictly according to the door manufacturer's instructions)
- Type and profile of glazing beads
- Type and mode of fixing for the beads
- For timber beads, the retaining screws, pins or nails must be angled to ensure that the glass is still held in place should the beads burn away

Introduction

- The amount of edge cover and edge clearance when glazed, especially for modified Soda Lime Silicate toughened fire-resistant glass types (typically 10mm for this type of glass)
- Quality of installation and workmanship

Note:

The final installation should reproduce the glazing assembly as approved. For example if a single pane is tested, an assembly containing shared transoms and mullions should not be installed.

What to look for on site

- Official evidence from a competent authority demonstrating the fire-resistant performance of the glazing system used
- Evidence of installer competence (e.g. UKAS-accredited certification body)
- Permanent stamp on the glass that indicates as a minimum, the name of the glass product and the manufacturer/supplier and possibly the fire performance rating
- The stamp must be visible and readable after glazing
- Marking of the impact performance class (i.e. class 1, 2 or 3 according to BS 6262 part 4 and EN 12600) where applicable
- Appropriate and proper storage of glass types and availability of appropriate handling equipment
- Full understanding and appreciation of health and safety aspects by those handling and installing fire-resistant glazing systems

Maintenance

- Visual inspection of glazing is required during routine fire risk assessments

Refurbishment

- Confirm with the 'Responsible Person' that the fire risks and fire hazards have not changed since installation of last refurbishment
- Any necessary refurbishments must be carried out according to the approved original specification for the glazing system and should be completed on a like for like basis
- All components must be replaced with a new, complete and approved fire-resistant glazing system if the original glazing system specification cannot be established or was originally specified incorrectly

Horizontal or Inclined Overhead Glazing

Fire resistant glazed systems are normally used in vertical locations but horizontal and inclined glazing are possible using specialist systems. Contact manufacturers for details.

Introduction

Always

- Install the fire-resistant glazing system according to configuration, design and materials as tested or assessed
- Ensure that the manufacturer's installation instructions are followed

Never

- Approve and use a fire-resistant glazing system that does not have relevant and applicable evidence of performance
- Substitute one glass for another, even if they have nominally similar specifications without appropriate test evidence
- Assume that standard impact safety toughened or safety/security laminated glass is fire rated
- Use standard, non-rated glazing seals and bedding materials
- Allow the mixing and matching of components between different approved fire-resistant glazing systems
- Allow on-site modifications which are not approved
- Install insulation performance glass in an integrity only rated frame system where the requirement is for an insulation performance assembly
- Apply surface treatments or modifications to the glass after installation unless approved and endorsed by the glass manufacturer

Section 1

Principles

Section Contents:

- Design Flexibility
- Planning
 - ◆ New Build
 - ◆ Refurbishment
 - ◆ Upgrade
- Fire-resistant glazed systems
- Responsibilities
- Main components of fire-resistant glazed systems
- Application
- Applicable standards for fire-resistance
- Regulations covering fire safety
- Classification of fire-resistance for UK regulations
- Approved Document B (England and Wales)
- Building Standards (Scotland)
- Fire safety legislation
- Building Regulation 38 (formerly 16B)
- Classification of fire-resistance to European standards
- Property protection

Design flexibility

The use of fire-resistant glazed systems encourages freedom and flexibility of design because of the unique performance range of glass, whilst providing the means to satisfy fire safety and other functional performance benefits at the same time. It is sometimes far too easy to assume that fire safety regulations impose a straightjacket on design. This is far from being the case when fire-resistant glass is used.

There are a large number of approved fire-resistant glazed systems available based on a varied range of fire-resistant glasses. Choice is far from restricted design innovation and creativity can be advanced, rather than inhibited, by choosing one of the many different fire-resistant glazed systems.

Some types of fire-resistant glass have a wider range of approved glazed system solutions than others, and the performance capabilities can also vary tremendously from one glass type to another. An assumption must never be made that what can be achieved with one fire-resistant glazed system can be automatically achieved with another. Direct dialogue with glass manufacturers, or their agents, to identify the range of approved glazed systems that are possible is therefore always advisable and recommended.

Planning

Consideration must be given to the required fire-resistant glazed elements at an early stage in project planning and specification. This should include all aspects of specification and supply, in addition to those directly related to realizing the required design performance. Important factors to take into account from the outset include

Best Practice Rule No. 1

Only use fire-resistant glass as part of a fire-resistant glazed system and ensure that all components are compatible.

Section 1

Principles

procurement, ordering, delivery, handling and site storage. All preparations should be carried out in good time; last minute changes or adjustments should be avoided otherwise the building performance may fall short of the requirements.

Suitable delivery and lead-times should be built into the project plan and agreed with the supplier in good time before expected arrival time on site in recognition that fire-resistant glazing systems are special high performance products based on several matched components.

New Build

Specification based on the guidance contained in Approved Document B (ADB), BS 9999 or an evaluation by a Fire Safety Engineer. Insurers may also have their own requirements for enhanced property protection.

The fire protection measures will be specified by the buildings architect/designer, based on the statutory requirements of the Building Regulations. Compliance with these regulations may be achieved through the use of details contained in Approved Document B, BS 9999 or through assessments conducted by Fire Safety Engineers. To ensure satisfactory performance use the guidance contained within this document in respect of specification and installation.

Building Refurbishment

Specification based on the guidance contained in Approved Document B (ADB), BS 9999 or an evaluation by a Fire Safety Engineer. Insurers may also have their own requirements for enhanced property protection.

If a building is undergoing a full refurbishment and/or a change of use, the same Building Regulation requirements relating to New Build will apply. The fire protection measures will be specified by the architect/designer based on the statutory requirements of the Building Regulation. Compliance with these regulations may be achieved through the use of details contained in Approved Document B, BS 9999 or through an assessment carried out by a Fire Safety Engineer.

Alternatively the refurbishment may be localised to only a few items which will either be Upgrades, where newly specified products replace the old ones or Replacements where new or equivalent products are substituted for existing. In both cases it is necessary to establish the degree of fire protection required from a record of the original specification or more likely from a recent risk assessment carried out by a competent person. The guidance given in the relevant sections of this Best Practice Guide can then be used to ensure the correct products are specified and installed.

Upgrade or replacement

Following a risk assessment by a competent person, a visit by Fire Brigade or a requirement from the buildings insurers, the current level of protection has been identified as being insufficient and it is required to be upgraded.

Following a Risk Assessment carried out by a competent person, a visit by the Fire Brigade or a requirement from the buildings insurers, it may be necessary to make

Section 1

Principles

glazed products fire resistant or the level of fire resistance increased. This may be because the wrong product was originally specified or installed, or the use of the space has changed since the specification was determined.

Initially the new required specification must be established in terms of type of protection required, integrity only or integrity with insulation and the length of time of protection required.

Evaluate the current installation to determine what level, if any, of fire resistance is currently provided, e.g. if timber doors are currently fitted, a 54mm thick fire door is likely to be a 60 minute fire door whereas a 44mm door is likely to be a 30 minute fire door. Always check for labels or other indicators such as plugs, which will enable the performance rating to be confirmed.

Timber screens are more difficult to assess as these are purpose built based on an original fire test or assessment, and therefore unless details of the original build are available, the assessment needed will be based on the knowledge and experience of the person carrying out the survey/assessment. Generally the minimum timber section of a 30 minute screen is 80mm x 25mm and 90mm x 45mm for a 60 minute screen. If these basic requirements are met, examine the current glazing detail, if they are not correct the project must be treated as a Building Refurbishment.

If insulation is required and the glass is not identifiable as an insulating glass, it must be replaced with a suitable product for the fire resistance specification required (see table 2 in section 3 of this Guide for a list of suitable glasses and manufacturers).

In some cases the edge cover is important, contact the glass manufacturer/supplier to confirm.

There should be appropriate fire rated glazing seals between the glass and beads. These will often be intumescent glazing seals but can be other materials such as rubber. However, in all cases they must have been the subject of a fire test in a glazed application to either BS 476-20 or EN 1364-1. If the glazing specification is for a 60 minute resistance, the glazing rebate should also be lined with an intumescent liner strip as shown in Fig 6 section 5.

For metal screens and doors, the original manufacturer should be identified and the installation details checked against their specification, which has been determined by fire test or assessment.

Fire-resistant glazing systems

Fire-resistant glazing provides excellent protection for lives and property in the event of fire.

The fire environment is a hostile one for all materials and its occurrence and development is essentially unpredictable with uncertain outcome.

It is therefore critical that the specification, selection, and installation of fire-resistant glazing are all carried out with close attention to detail.

Fire-resistant glass can only achieve its designed performance when it is part of a complete fire-resistant glazed system. This means that all component parts, such as the glazing seal, beads, fixings, and frame material, must all be compatible and work together to achieve the required performance.

Section 1

Principles

The fire-resistant glazed system must also be installed as tested or assessed by an appropriately qualified authority. Different types of fire-resistant glass may require different glazing details, e.g. concerning glass edge cover, which must not be changed or assumed to apply to other glass types.

Installation must be carried out by competent individuals who can demonstrate the necessary knowledge and skills (see Section 9).

ALWAYS:

- Check with the supplier that there is relevant and appropriate evidence of fire-resistance performance.
- Ensure correct installation of the glazed system, which is fundamental to the achievement of its stated fire-resistance performance.

NEVER:

- Assume that the substitution of one component for another will result in the same level of fire-resistance, even if the components in question are nominally similar.
- Mix and match components from different approved systems.
- Be tempted to take short cuts by reducing the performance specification.

Responsibilities

There is a shared duty of care incumbent on all those involved in the specification, manufacture, testing, supply and installation of fire-resistant glazed systems, to ensure that the final installed system is fit to protect the building and its occupants against the effects of fire.

All those involved in the process need to be aware of their individual responsibilities and obligations, in particular taking particular responsibility for the consequences of what they do, or might not do, concerning the fire-resistance performance of the glazed system in the event of a fire.

Section 1

Principles

Glossary of terms

The cross sections in Figures 1 and 2 show fire-resistant glazed systems labelled with most commonly used terms and components. These terms are used throughout this best practice guide.

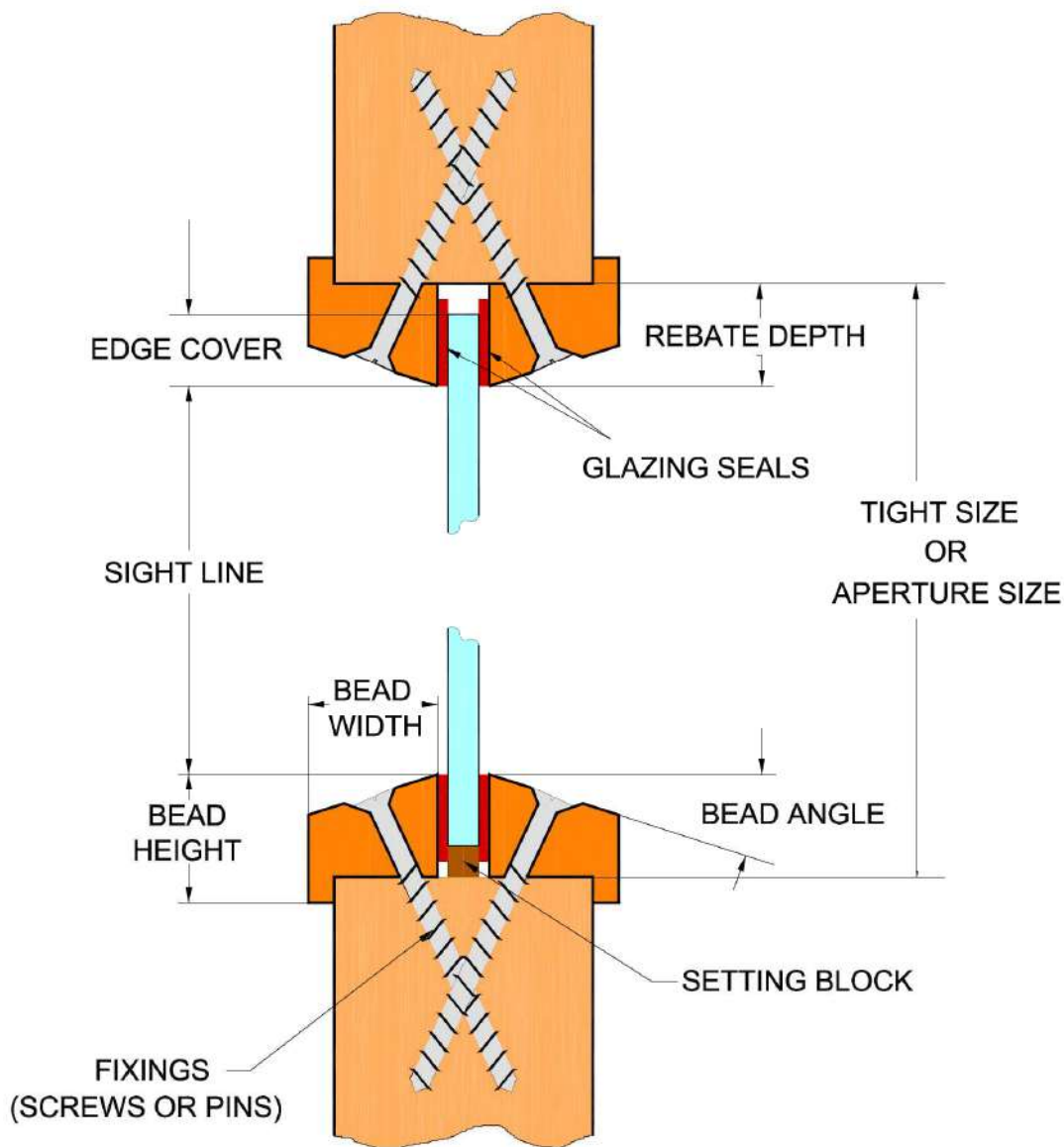

Figure 1 – Example components of a typical glazed timber door leaf

Section 1 Principles

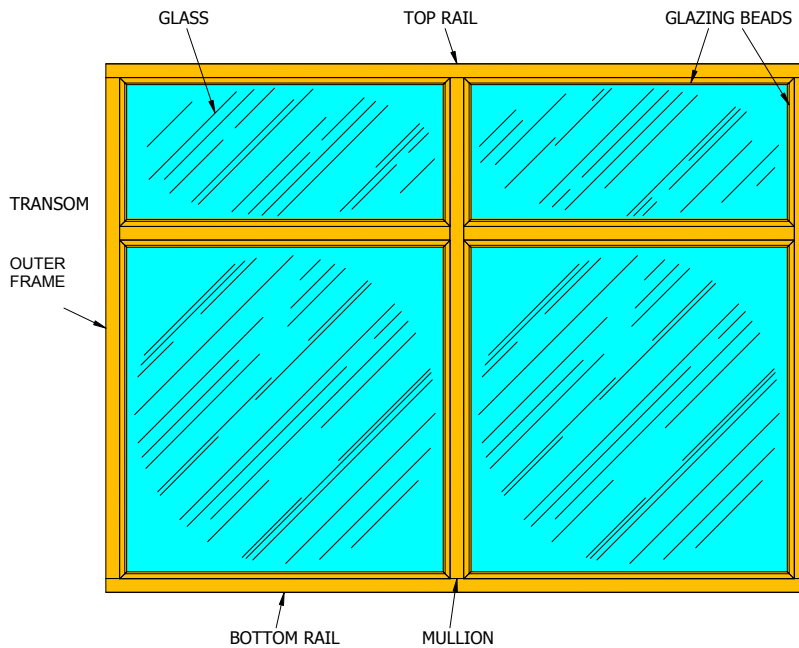

Figure 2 – Example of typical glazed timber screen

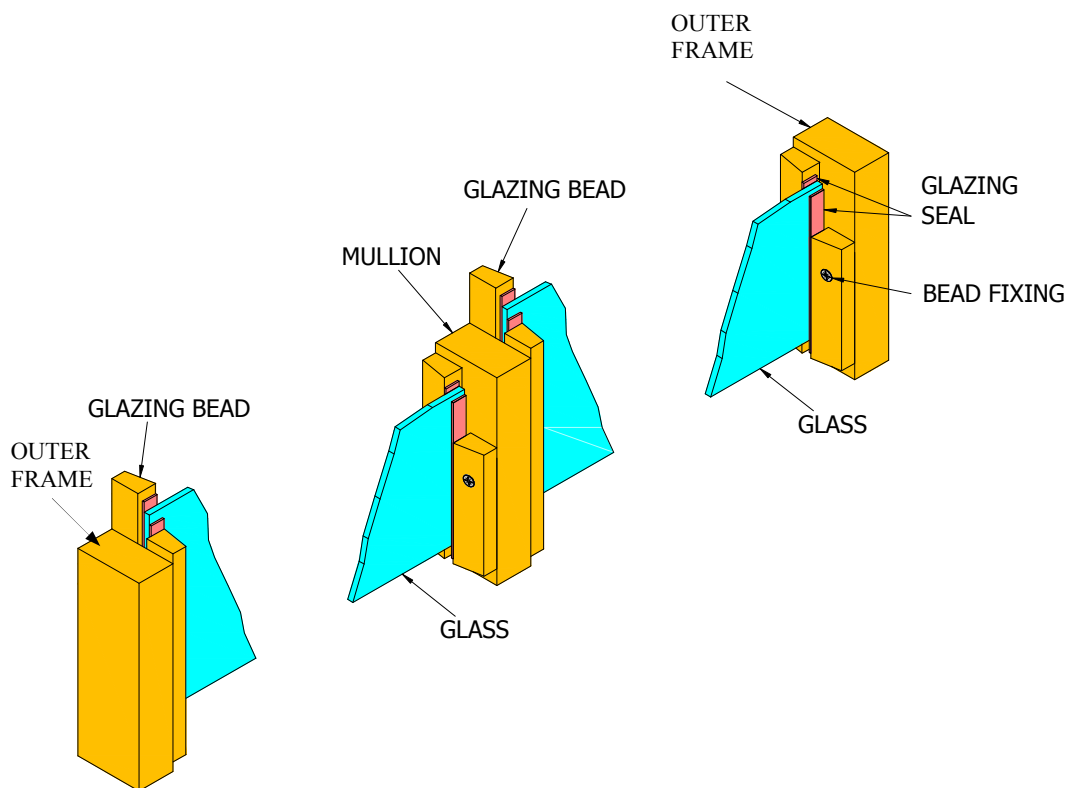

Figure 2a – Horizontal section through glazed timber screen

Section 1

Principles

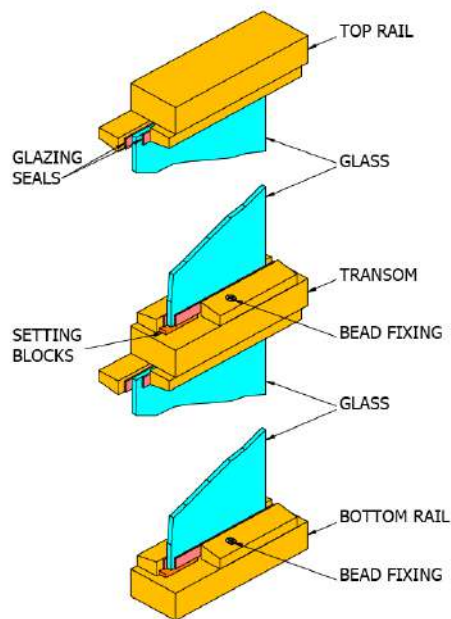

Figure 2b – Vertical section through glazed timber screen

Applications

The glass must be tested and classified in a proposed end-use application, e.g. screen, door, roof, floor, or façade in a glazed system appropriate for that application.

Any test or assessment report for one application must not be used to cover other applications.

Approval in a vertical orientation must not be taken to imply approval in a horizontal or inclined orientation.

Key factors that influence fire-resistance of glazing systems

- Maximum pane area
- Glass pane aspect ratio
- Fenestration layout and overall size of screen
- Type of glazing seal
- Frame material
- Frame design and construction
- Type and shape of beads
- Extent of glass edge cover (for example, for modified toughened soda-lime glass)
- Type, location and application of fixings for both frame and beads
- Type of door materials and construction
- Orientation – Vertical, Horizontal or Inclined

Section 1

Principles

Applicable standards for fire-resistance

Fire-resistance is a characteristic of an element of construction or of a complete assembly. A classification of fire-resistance for the glass in isolation is therefore not possible.

Fire-resistance is always stated with reference to defined criteria which can only be determined on the basis of a furnace test carried out in accordance with a given test standard. Relevant standards for the UK are as follows:

- BS 476-22, *Fire tests on building elements and structures – Methods for the determination of fire-resistance of non-load bearing elements of construction.*
- BS EN 1363-1, *Fire –resistance tests – General requirements*
- BS EN 1363-2:, *Fire-resistance tests – Alternative and additional procedures*
- BS EN 1364-1, *Fire-resistance tests for non-load bearing elements – Walls*
- BS EN 1634, *Fire-resistance tests for door and shutter assemblies – Fire doors and shutters*
- BS EN 13501-2, *Fire classification of construction products and building elements – Classification using data from fire-resistant test, excluding ventilation services*
- BS EN 1365-2, *Fire-resistance tests for load bearing elements – Floors and roofs*

England and Wales

Building Regulations 2000, Approved Document B (ADB), Fire Safety, 2006 edition

Scotland

Technical Standards

Domestic and Non-domestic section 1 (structure), 2010

Domestic and Non-domestic section 2 (fire), 2010

Northern Ireland

Building Regulations Part E Fire Safety

Regulations covering fire safety

The UK Building Regulations are covered by three separate documents, based on common principles with differences only in points of individual detail:

The principles can be illustrated by reference to Approved Document B (ADB).

Classification of fire-resistance for UK Building Regulations

Integrity is the ability of a material to withstand fire exposure on one side without the transmission of fire as a result of the passage of flames or hot gases. An integrity barrier acts in effect to physically stop fire movement. Alternatively, integrity may be referred to as non-insulating.

Section 1

Principles

Insulation is the ability of a material to withstand fire exposure on one side without the transmission of fire to the unexposed side by limiting heat transfer due to conduction, convection or radiation (in addition to integrity).

Note: Fire performance insulation must not be confused with the energy insulation requirement of insulating glass units for external glazing to reduce energy losses from buildings (Conservation of fuel and power). Also fire resistance is not solely a function of time. Specifications must always specify time, integrity and insulation (where appropriate).

Achievement of the insulation criterion is measured by thermocouples on the cold face of the glass and frame. To achieve the requirements of insulation, the average temperature rise across the glass face or frame must remain below 140°C, with no point rising by more than 180°C above ambient.

Note: Failure of insulation does not necessarily mean that integrity failure has occurred.

For the purposes of UK Building Regulations, performance is defined in terms of:

- either Integrity only
- or Integrity and Insulation

at a standard test time period, e.g. 15, 20, 30, 60, 90, or 120 minutes according to the building type, the application (e.g. walls, doors, floors) and location (e.g. internal or external, corridor, lobby or stairway).

The final classification may be expressed in a concise form as follows, for example:

- 30 minutes integrity and 30 minutes insulation, “30/30”
- 30 minutes integrity only, no insulation, “30/0”.

Approved Document B (England and Wales): 2006 edition

Approved Document B (AD B), or its equivalent in Scotland and Northern Ireland, is the main point of guidance for compliance with Schedule 1 to the Building Regulations 2000. Volume 1 Edition 2006 - dwellinghouses or Volume 2 Edition 2006, amended 2007 - buildings other than dwellinghouses.

Building Regulations are intended to ensure that a reasonable standard of life safety is provided in the event of fire. The guidance in AD B provides methods to achieve compliance and apply to common building situations. There is no obligation to adopt any particular solution contained in the approved document but in that case complying with the relevant functional requirement should be met in some other way, with associated substantiation and evidence. This would normally include either specific system and assembly testing or a more wide-ranging engineering-based evaluation.

Property protection is not specifically included within the scope of regulatory guidance and additional measures are therefore often required beyond those required for life safety.

The main provisions of AD B are to achieve a safe structure in the event of fire, to:

- Allow occupants to reach a place of safety
- Prevent structural collapse for a sufficient time period to allow evacuation

Section 1

Principles

- Limit further fire spread
- Provide satisfactory means of access for fire-fighters

Particular appendices and tables in AD B relevant to fire-resistant glazed systems are:

- Appendix A, Performance of materials, products and structures
- Table A1, Specific provisions for fire-resistance of elements of structure
- Table A2, Minimum periods of fire-resistance
- Table A4, Limitations on the use of un-insulated glazed elements on escape routes
- Appendix B, Fire doors
- Table B1, Provisions for fire doors.

If specifiers choose not to follow the guidance in Approved Document B then it is their responsibility to demonstrate that the functional requirements of Building Regulations are met in some other way, with the associated substantiation and evidence.

This would normally include either specific system and assembly testing or a more wide-ranging engineering-based evaluation.

Part B1	Means of Escape	Insulating and/or non-insulating glass types can be used in lobbies, corridors and stairways. Guidance typically is for a minimum of 30 minutes fire-resistance
Part B2	Internal fire spread (linings)	Glass is a material of limited combustibility which satisfies the requirements of the highest performance class for surface spread of flame (i.e. Class 'O'), provided that there is no coatings or decoration that change it's combustibility.
Part B3	Internal fire spread (structure)	The requirement for separation between compartments must be for integrity and insulation up to a maximum of 120 minutes, depending on situation. Various glass types can provide fire resistance up to these levels of performance. The relevant fire protection strategy is compartmentation (i.e. a fire control and separation strategy to prevent fire spread by restricting fire to its area of origin).
Part B4	External fire spread	This refers to the control of fire spread from building to building by using fire-resistant products and classified surface spread of flame products when close to facing buildings and relevant boundaries, according to defined distance criteria. Additional measures to prevent fire movement in the same building (e.g. use of fire-resistant glass facades) may also be relevant.
Part B5	Access for fire brigades	Access for fire-fighters into buildings is provided by fire safety access routes brigades which require integrity and insulation as well as a Class 'O' surface spread of flame. Some fire-resistant glass types can meet these requirements up to a maximum of 120 minutes, if necessary.

Table 1: Sections in Approved Document B relevant to fire-resistant glazed systems.

Section 1

Principles

A summary of the range of applications for fire-resistant glazed systems is given below and Figure 3 shows an example of typical functional performance guidance.

Summary of applications for fire-resistant glazing systems Reference Approved Document B (or equivalent)
Means of escape <ul style="list-style-type: none">• Corridors• Doors• Stairwells• Lift shafts• Protected lobbies leading to a protected stairway• Protected refuges for phased evacuation
Fire containment compartments <ul style="list-style-type: none">• Fire walls and protected openings in compartment walls
Fire separation <ul style="list-style-type: none">• Protected areas within compartments• Enclosures for spaces of special fire hazard• Floors and horizontal glazing panels• Separation of new storeys in existing dwellings
External building envelope <ul style="list-style-type: none">• Walls• Doors• Skylights• Roofs• Façades
Fire-fighter access <ul style="list-style-type: none">• Protected shafts and corridors
Load Bearing Fire Resistant Glass Floors <ul style="list-style-type: none">• Lobby areas leading to protected shafts

AD B, as issued in April 2007, is in two volumes: volume 1, dwelling houses; volume 2, buildings other than dwellings. Particular points of guidance relevant to best practice are as follows:

- The need to carry out any building work in compliance with Regulation 7, with proper materials and in a workmanlike manner
- Recommendations on the role of independent schemes of certification for products and accreditation of installers, as a way of providing evidence for the confidence of Building Control in satisfying themselves of compliance with regulations
- The provision of appropriate information and documentation for effective fire safety management of the building (Regulation 38)

Section 1

Principles

- The importance of inclusive design (e.g. taking into account Part M of the regulations, Access to and use of buildings)
- Advice that fire-resistant glass should be marked with manufacturer and product name, ADB - Vol 2 - Table A4 and section 9 of this guide
- A reminder that additional measures are often required and that insurers may ask for higher standards
- Compartment walls should be able to accommodate the predicted deflection of the floor above (section 8 of this guide)

Note: Approved Document B can be accessed on the Communities and Local Government web site, www.planningportal.gov.uk

Section 1 Principles

Example - A single storey shop with office and storage areas

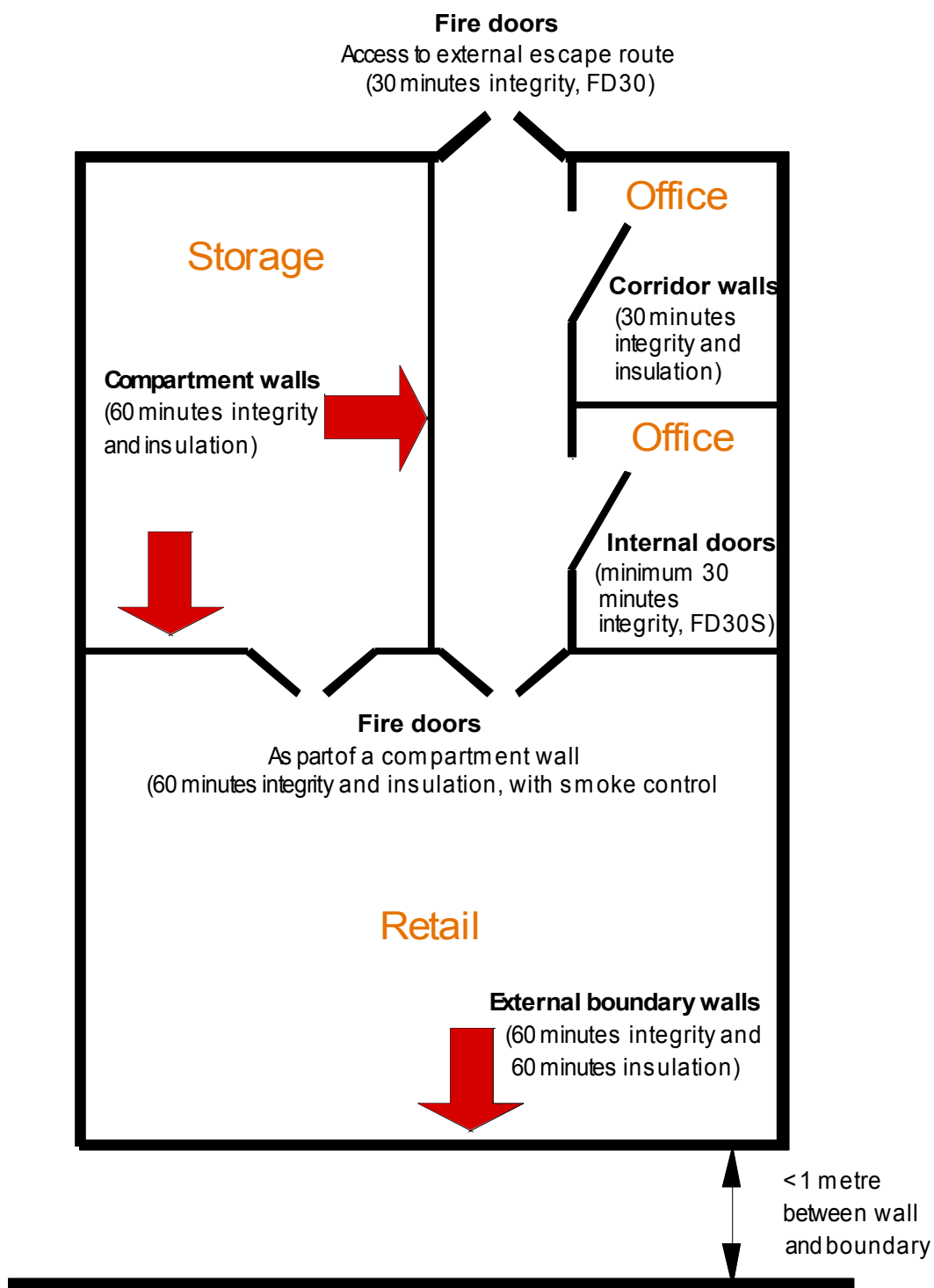

Figure 3: Building plan showing possible fire-resistance requirements

Section 1

Principles

Fire safety legislation: The Regulatory Reform (Fire Safety) Order

Ongoing control of the occupied building for effective fire safety, after design and construction, is provided by the Regulatory Reform (Fire Safety) Order 2005, which came into force on 1st October 2006. This order applies to England and Wales and covers all non-domestic premises, including the common parts of premises that contain one or more dwellings. (Separate laws apply in Scotland and N Ireland.)

The FSO is now the dominant piece of legislation governing fire safety, replacing previous legislation such as the Fire Precautions Act 1971 under which fire certificates were previously issued for defined building categories. It brings fire safety into line with established health and safety principles and accordingly introduces a methodology based on risk assessments for fire safety embracing fire precautions, management, protection and preventative measures, training, and information.

Responsibility and accountability for compliance with the statutory requirements rests with the person who is directly responsible for the building (normally the owner or employer, as applicable, defined as the Responsible Person). Inspection and enforcement powers rest with the Fire and Rescue Service, including the facility to impose enforcement orders in cases of non-compliance.

Significantly, the provisions of the order cover contractors carrying out refurbishment or re-construction work within the building, to ensure that the fire safety provisions are not impaired by such work. This could specifically cover, for example, replacement glass, repair of installed fire-resistant glazed systems and new glazed doors or partitions. *See separate guidance section 9.*

Note: Guidance documents can be accessed on the Communities and Local Government web site, www.communities.gov.uk/fire

Section 1

Principles

Building Regulation 38 (formerly 16B) - Fire Safety Information

Approved Document B (2006) has been produced on the assumption that the building concerned will be properly managed for life safety throughout its working life. This applies in particular to the provision of information on the design and construction of buildings which are covered by the Regulatory Reform (Fire Safety) Order 2005, where the work potentially affects life safety. Regulation 38 (formerly Regulation 16B) provides this link and its stipulations are mandatory. It is clearly of fundamental importance for the Responsible Person to be made aware of both the details of installed fire safety measures and applicable underlying assumptions.

The objective of Regulation 38 is to ensure that relevant information produced at the construction stage is passed on to the Responsible Person so that the risk assessment process can be as fully informed as possible. The regulation is obligatory and applies to the information that should be provided on initial construction, extension or material change of use.

General guidance on the type of information to be provided is given in Appendix G of Approved Document B (2006 edition), volume 2.

For best practice in fire-resistant glazed systems, the GGF would expect the following information to be provided by the installer:

- A precise description of the fire-resistant glazed system as installed, with a listing of all the key components by name and manufacturer (i.e. glass, glazing seal, frame, type of fixings and their specification, beads and fixings of the frame to the surrounding structure)
- For timber frames, the type of timber and its nominal density
- Location of the glazed system, ensuring correct recording on associated plans
- Marking of the fire-resistant glass, to be clear and visible after glazing (reference AD B - Table A4 and section 9 in this guide)
- Statement of the classified fire performance of the glazed system
- Evidence of the classified performance, either with the relevant test report or reference to where the test report can be obtained if necessary
- Statement of performance for other key properties, e.g. for impact safety, acoustic insulation, use as a barrier (Appendix B)
- Relevant guidance on maintenance and upkeep of the system during its working life
- Special guidance on replacement or refurbishment, if applicable. (Note: The normal GGF recommendation is to replace the glazed system as originally specified or replace in its entirety, see section 9).

Section 1

Principles

Classification of fire resistance to harmonised European Norms (hEN's)

The European classification standard BS EN 13501-2 includes a provision for both integrity and insulation according to the same definitions applicable to UK regulations. Under the European scheme, the symbol **E** is assigned to integrity and **I** to insulation.

Provision is made within the classification scheme defined in this standard to use a range of standard test time periods, i.e. 15, 20, 30, 45, 60, 90, 120, or 180 minutes.

BS EN 13501-2 also introduces a supplementary criterion of radiation (designated by **W**) to cater for those limited number of countries whose national regulations require this performance category. Radiation is defined as the ability of a material to withstand fire exposure on one side and reduce the probability of transmission of fire by significant heat radiation to adjacent materials. Radiation must be determined by measurement in a standard fire test.

An element which meets the insulation criterion is automatically deemed to meet the radiant heat criterion without measurement.

Product classification to BS EN 13501-2 can then be described using shorthand as follows, for example:

- Integrity only for 30 minutes, "E30"
- Integrity and radiation protection for 30 minutes, "EW30"
- Integrity and insulation for 30 minutes, "EI30".

An amendment was issued to Approved Document B in 2006 to provide visible recognition to the new European technical specifications, classification standards and supporting fire test methods, which have been developed in support of the Construction Products Directive (CPD). Table A1 in the amendment provides the minimum provisions expressed in terms of the classification scheme given in BS EN 13501-2 when tested to the relevant European standard. There are no changes to the minimum periods of fire-resistance given in Table A2.

Note: Approved Document B can be found on the DCLG planning portal web site: <http://www.planningportal.gov.uk>

Section 1

Principles

Radiant heat and BS EN 13501-2

The radiation performance category (W) is defined in BS EN 13501-2 at a qualifying maximum total heat flux of 15 kW/m². Values are determined on the basis of measurements according to BS EN 1363-2 at a standard distance of 1 metre from the glazed element at the end of the standard fire test time period (e.g. 30 or 60 minutes as appropriate). This criterion can be achieved by only certain types of integrity glass (and automatically by using an insulation glass). It is not necessary to measure radiant heat (W) from insulation glazed systems because the total heat flux for such products is so low (typically less than 1 kW/m²).

Guidance in UK Building Regulations (e.g. Approved Document B, or equivalent) does not include radiation.

For those countries where the fire regulations require a radiation performance category, then this is typically applied at boundary conditions and along fire escape routes to allow for the safer passage of people in the event of fire, when compared with basic integrity function.

Where levels of radiant heat are concerned, there are major differences between insulation (EI) and integrity (EW) glass types. The EW category should not, under any circumstances, be seen as a lower level of insulation performance. The EW category is a diffuse one: the maximum limit allows inclusion of glazed elements with measured radiant heat values from, for example, 3 kW/m² up to 15 kW/m² without differentiation; radiant heat depends on critically on glass area, aspect ratio, orientation and distance from the glass surface; and all integrity glass types can be included within the classification by choosing an appropriate glass radiating area. The EW classification is therefore a feature of the particular glazed element that has been tested and not a fundamental glass characteristic.

Property protection

The primary emphasis of Approved Document B or equivalents in Scotland and Northern Ireland is the prevention of injury and death in the event of fire, although a by-product of these requirements can be that the structure of the building and its contents usually benefit from a degree of protection from fire as well.

Although performance based fire safety engineering can be used to deliver the same level of life safety, it may dispense with building or content protection. This may also compromise the ability of a business to continue to trade. Therefore issues concerned with property and asset protection and business continuity fall are of particular concern of insurers and they may impose their own design requirements in relation to fire protection. The overall requirements can be addressed through a Qualitative Design Review (QDR) where the scope and objectives of the fire safety design are defined and where performance criteria are established and acceptance criteria set.

It is likely that insurance surveyors will make reference to the guidance contained in "Design Guide for the Fire Protection of Buildings" published by the Fire Protection Association (FPA) on behalf of the Association of British Insurers or "Approved Document B: Fire Safety (Volume 2) - Buildings other than dwellinghouses Incorporating Insurers' Requirements for Property Protection" when assessing potential insurance liability of a

Section 1

Principles

building. This publication is produced by RIBA Publishing in association with RISC Authority and FPA. FRGG supports the 12 essential principles for fire protection which have direct relevant to the application of fire-resistant glazed systems. These are as follows:

Reaction in the event of fire

Principle 1

The building shall be constructed in such a manner that if a fire starts, the extent of fire and smoke damage will be minimised and confined as close to the source of fire outbreak as is practical/feasible.

Principle 2

With the exception of joinery products, the building shall be constructed from building materials/products that will not make a significant contribution to the early stages of a fire or contribute to the spread of fire.

Principle 3

Suitable measures will be taken for the prevention of premature structural collapse and excessive deflection.

Principle 4

Consideration should be given at the design stage regarding potential damage from firefighting water and to ensure as far as practical that the effect on the environment of the fire effluent will be minimised.

Workmanship

Principle 5

As a minimum, all fire protection products shall be third-party certified to an appropriate product or performance-based standard (attestation level 1 for CE marking).

Principle 6

All fire protection products/systems shall be installed by adequately trained specialist installers.

Response to fire

Principle 7

The building shall be fitted with an appropriate automatic fire alarm system.

Principle 8

The fire protection systems shall be regularly maintained so that they are able to perform their intended function throughout the life of the building.

Section 1

Principles

Fire prevention

Principle 9

There shall be adequate provision to prevent an arson attack.

Principle 10

The building shall be so constructed that fire spread into the premises from an adjoining building .

Fire safety management

Principle 11

The building owner shall ensure an adequate standard of fire safety management throughout the life of the building.

Principle 12

Any fuel-burning appliance and services or electrical appliance and services shall be designed, constructed and installed in a manner that reduces their potential as an accidental source of ignition.

Section 2

Evidence of Fire Performance

Section Contents:

- Introduction
- Test reports
- Assessment reports
- Third-party certificates
- CE Marking process
- EC Certificate of Conformity
- Classification report
- EC declaration of conformity
- Field of application
- CE Marking and harmonised European Product Standards and European Technical Approval Guidelines

Introduction

The guidance given in Approved Document B (England and Wales) or the equivalent for Scotland and Northern Ireland is that fire-resistance performance is determined by reference to tests either in British Standards, i.e. BS 476 series, or European Standards, i.e. ES EN 1364 for walls or BS EN 1634 for doors. With the emergence of the European market the European tests are becoming more prevalent and GGF members conduct fire resistance tests to EN standards for future applications. Test evidence generated to these Standards may be used to generate a number of different documents that demonstrate the product performance claims. These are:

- A test report
- An assessment report
- A certificate provided by a third-party product certification scheme (this is normally voluntary)
- An EC Certificate of Conformity (used only for CE Marking and therefore is a mandatory requirement in most European Countries)
- A classification report (in accordance with BS EN 13501-2)
- A manufacturer's declaration of conformity (used only for CE marking and therefore is a mandatory requirement in most European countries)
- A direct and/or Extended Application report (in accordance with BS EN 15254-4 for glazed partitions or BS EN 15269-2 or 3 for steel or timber doorsets respectively)

Best Practice Rule No. 2

Always make sure that there is relevant evidence of performance for the installed glazed system, based on test data.

Symmetry of test samples

If the glass or frame is asymmetrical in cross-section then the glazed system should either be tested with both sides towards the fire or if it has been established that one orientation has a lower performance than the other, with that side towards the fire. Appropriate installation instructions should be provided accordingly.

Section 2

Evidence of Fire Performance

Test Reports

Fire-resistant glazed system test reports should only be accepted if they are from an appropriately accredited test laboratory, e.g. a Notified European Test Laboratory or one accredited by UKAS. The test report is only applicable to the specific system as tested and the evidence provided therein should not be used beyond the specific application tested. Test reports are confidential to the sponsor of the relevant testing and must not be used in support of a particular construction without their permission.

The test report is only applicable to the specific system as tested.

Test reports are confidential to the sponsor of the relevant testing and must not be used in support of a particular construction without their permission.

Assessment Reports (in-lieu of fire resistance tests)

Fire resistant glazing systems have a range of possible variations suitable for particular applications. These variations may be cosmetic features with no significant effect on performance or more fundamental changes which are likely to influence fire performance, such as bead thickness or timber treatment. The range of possible variations makes it uneconomical to test all options and in some cases, the glazed assembly may be too large to test in the available test furnaces.

In these cases, variations to the tested system may be approved on the basis of technical assessment to the appropriate standards, using the test evidence that is available.

The Passive Fire Protection Federation

The Passive Fire Protection Federation (PFPF) gives guidance on the preparation of assessments and how to use assessments. The GGF, as a member of the PFPF, recommends that only assessments which comply with this guidance should be used in support of glazing system performance claims.

www.pfpf.org.uk

The fundamental guiding principle governing assessments is that the assessed performance would be achieved if the glazing system were to be tested.

The following points should be kept in mind when referring to or relying on assessment reports:

- Assessment reports must only be carried out by appropriately qualified persons who can demonstrate the necessary knowledge and experience of fire-resistant glazing systems
- Only assessments carried out to the criteria defined by the Passive Fire Protection Federation should be used (PFPF Guide to Undertaking Assessments in-lieu of Fire Tests)
- The use of test data from tests that are not observed by the responsible assessment authority is not best practice
- The test data must be relevant and applicable both to the glazed system under consideration and its proposed application
- Assessments may be either interpolation between test data or extrapolation from test data

Section 2

Evidence of Fire Performance

- Test data relating to one type of glass must not be used to support the application of another
- If test evidence that contradicts the conclusions of the assessment subsequently becomes available then the assessment must be withdrawn
- An assessment gives no guarantee concerning the system's consistency of manufacture

Third-party certificates

These relate to national schemes developed by certification bodies to provide reassurance relating to the manufacturing process and product consistency of fire-resistant glazing systems. Third Party Certification is a higher level of attestation than tests and/or assessments used in isolation. The requirements of certification should include fire performance and other relevant key parameters (especially impact safety and durability). The use of appropriate third-party product certification schemes is recommended, as these can help to ensure that products are made consistently, that their intended end use is supported by appropriate test evidence and that this end use is properly defined. Appropriate third party product certification schemes within the UK include:

Appropriate product certification schemes include:

- CERTIFIRE, from Exova Warringtonfire
- QMARK, operated by BMTRADA
- BWF CERTIFIRE for timber doors
- The GGF endorses the above Certification schemes

Third party product certification schemes should:

- Be accredited by an accreditation body, e.g. UKAS or equivalent
- Include independent sampling and testing of fire performance of the glass
- Include independent testing and sampling of other key properties relevant to the application (e.g. impact safety and durability)
- Require surveillance of the factory production control system by scheme personnel (or their authorised representatives) to check product consistency
- Require auditing of independently selected glass product from either the production line or the market (as required)
- Refine scheme qualification criteria
- Define procedures in the event of demonstrated non-compliance including the possibility of product recall if necessary

Section 2

Evidence of Fire Performance

CE Marking process - *at time of publication CE marking is not a requirement in the UK*

EC Certificate of Conformity

This is a document signed by a Notified Certification Body (i.e. a body nominated and approved by Member State authority). It confirms compliance with the relevant European (EN) product standard, attests that the claims of the manufacturer are accurate and that the product has been manufactured using an appropriate factory production control system which meets the requirements defined in the relevant European product standard.

Classification Report

The European process requires a classification report to be issued following a successful test or series of tests. This is to convert the test results into a classification in accordance with EN 13501-2, applicable across the European Community. All the relevant tests used as a basis for the classification shall be referenced in the report. The classification report should contain a brief description of the tested element, test results and any Direct or Extended Applications (see below) that may determine the scope of the final classification. The classification is based on E to signify integrity, W to signify radiant heat and I to signify insulation. The appropriate classification letter is followed by a number which designates the standard test time period achieved (e.g. E 30, integrity 30 minutes; EI 30, integrity and insulation 30 minutes).

EC Declaration of Conformity

A declaration of conformity is signed by the manufacturer or supplier. This declaration can only be made once a Certificate of Conformity - which references an appropriate classification report - is available.

By signing this declaration the manufacturer/supplier is taking responsibility that the product will achieve its declared characteristics in the particular end use applications, as defined in the scope of the declaration. It refers specifically to CE Marking for the product in question.

Field of Application

This refers to the extent to which the results of test data can be used to provide increased scope of application for a specific fire-resistant glazed system. Using the test data as a basis, the field of application defines parameters such as the limits of glass size, frame requirements and supporting construction requirements.

There are two types of application:

- Direct application
 - BS EN 1364-1 and BS EN 1634-1 allow for certain extensions for the glazed system under consideration, according to specific clearly defined rules as defined in the test standards. These applications always apply to the test result and test report under consideration.

Section 2

Evidence of Fire Performance

- Extended application
 - Further extension beyond the direct field of application is possible but only on the basis of rules defined in accordance with BS EN 15254-4 for glazed partitions or BS EN 15269-2 or 3 for steel or timber doorsets respectively. These rules are based on the collective judgment and experiences of industry experts. Extended application applies to the data from one or more test results, and is only allowed within the scope of the provisions given in governing European standards. They are the equivalent of carrying out UK assessments, except that the extended applications are based upon published 'rules' and have validity across Europe.

CE Marking and harmonised European Product Standards and European Technical Approval Guidelines

EN standards apply across the European Economic Area (EEA) and are produced by the European standards body, CEN. Such standards are of four types, covering testing, products, classification, and Extended Application. The CE Mark demonstrates compliance with the European standards that have been developed under the Construction Products Directive (CPD). The prime objective of CE Marking is to facilitate cross-border movement of goods within the European Community by removing technical barriers to trade. The CPD is a European directive adopted by all member Governments by their national legislation. "Safety in case of fire" is one of the six essential requirements under the CPD. In order to be able to CE mark a product under the CPD it is required that a harmonised Product Standard or A European Technical Approval Guideline is available. For most glass products these are now applicable and therefore CE marking is mandatory in most European countries (the UK is currently a notable exception to this requirement unless products are offered for sale in other European countries).

CE Marking Summary

Process:

- Certification and supervision by a Notified Certification Body (NCB)
- Independent sampling of specimens for initial type testing, under the authority of a Notified certification Body
- Independent verification of factory production control, by a Notified Certification Body
- Tests to European Standards carried out at a Notified Test laboratory

Associated documentation:

- Test report(s) (from the Notified Test Laboratory)
- Extended Application report (if relevant)
- Classification report (from the Notified Test Laboratory)
- Certificate of Conformity (from the NCB)
- Manufacturer's declaration (provided by the manufacturer / supplier)

Section 2

Evidence of Fire Performance

Alternative Routes to Demonstrate Fire-Resistance Performance

Carried out by UKAS accredited body

Carried out by Notified Certification Body for CE Marking

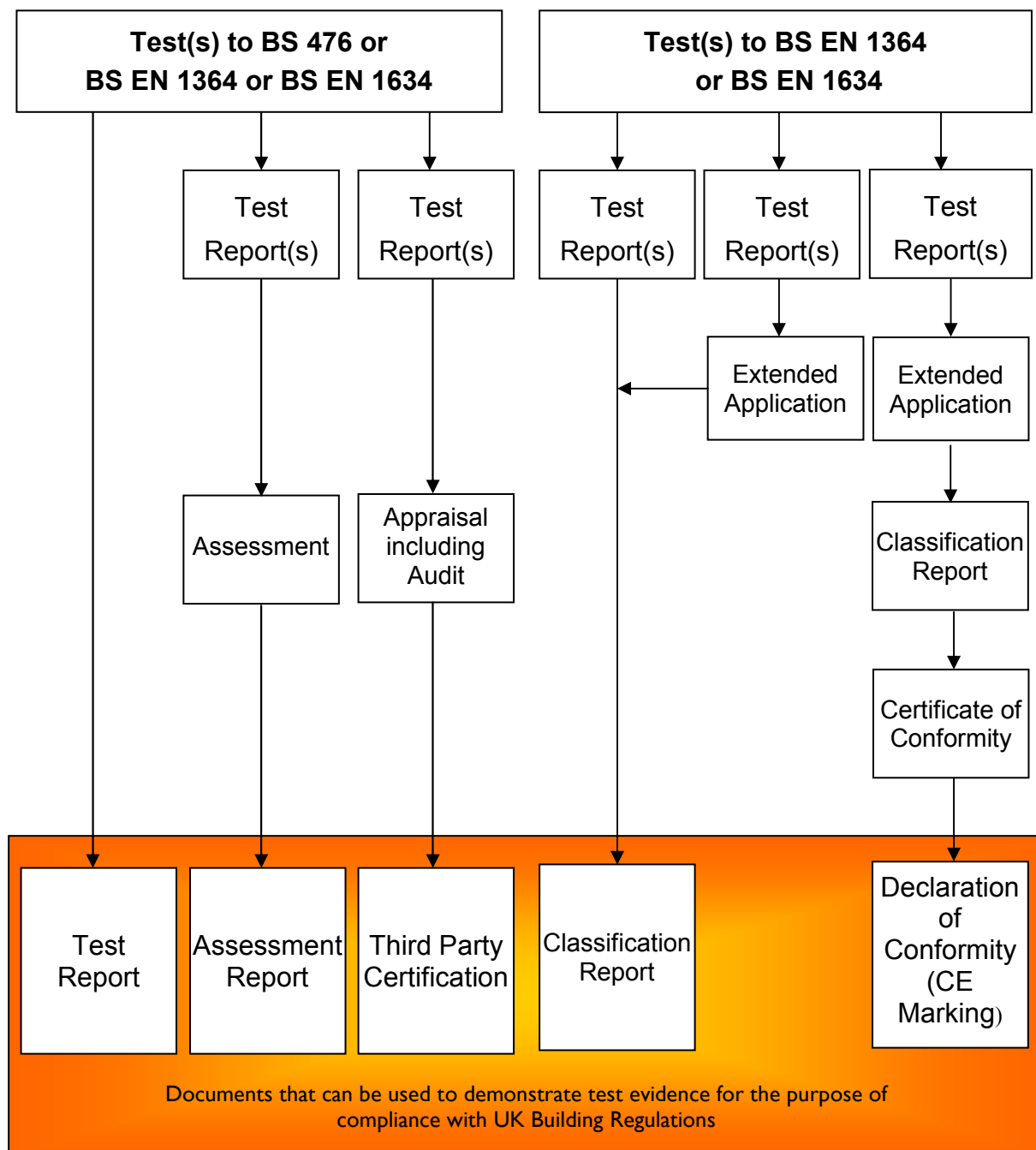

Table 3—Routes to demonstrate fire-resistance

Section 2

Evidence of Fire Performance

Notes:

- CE Marking is not a quality mark (although the process of demonstrating conformity does include elements similar to those normally associated with product quality schemes)
- CE Marking may only be claimed by the manufacturer through a 'Manufacturer's Declaration' which refers to a test report and a classification report provided by a Notified Certification Body
- CE Marking for glass products may be shown either on the product, or on packaging, or on associated documentation
- False declarations carry financial and/or custodial penalties, under the surveillance of Trading Standards

Section 3

Fire-Resistant Glass

Section Contents:

- Glass Types
- Performance in the event of fire
- Fire-resistant insulating glass
- Horizontal and sloped glazing systems
- Decorative treatments on glass
- Combining other performance requirements with fire-resisting glazing

Glass Types:

Fire-resistant glass can be based on a number of different glass technologies. These are summarised in tables 2 and 3.

Table 2: Glass types

Glass Type (relevant EN product standard in brackets)	Fire- Resistance	Trade Name	Manufacturer/ main FRGG supplier ref Ap- pendix A
Wired (BS EN 572-3 & BS EN 572-6)	Integrity	Pyrostem Pyroshield 2 Texture Pyroshield 2 Safety Clear	CGI International Pilkington Group
Ceramic (BS EN 1748-2-1)	Integrity	Firelite Firelite Plus Keralite FR	Southern Ceramic Supplies Vetrotech Saint- Gobain
Heat Soaked Thermally Toughened Soda Lime Silicate Safety BS EN 14179	Integrity	Vetroflam Pyroswiss	Vetrotech Saint- Gobain Vetrotech Saint- Gobain

Section 3 Fire-Resistant Glass

Glass Type (relevant EN product standard in brackets)	Fire- Resistance	Trade Name	Manufacturer/ main FRGG sup- plier ref Appen- dix A
Modified Toughened Soda Lime Silicate Safety (BS EN 12150)	Integrity	Pyrocet Pyrocet XP (T), (S), (R) Pyrosec Tempaflam Fireswiss	C3S Securiglass C3S Securiglass C3S Securiglass A C Yule CGI International
Resin Laminated BS EN 12543	Integrity	Pyroguard Wired Pyroguard Clear	CGI International CGI International
PVB Laminated BS EN 12543	Integrity	Pyroswiss Stadip Vetroflam Stadip	Vetrotech Saint- Gobain Vetrotech Saint- Gobain
Laminated Intumescent (BS EN 12543)	Integrity	Pyrobelite Pyrodur Pyrodur Plus Contraflam Lite	AGC C3S Securiglass Rankins Pilkington Anders Glass Nicholls & Clark Float Glass Ind. Vetrotech Saint- Gobain
Laminated Intumescent (BS EN12543)	Integrity & Insulation	Fireswiss Foam Pyrobel Pyrostop System Glass Pyranova Contraflam	CGI International AGC C3S Securiglas Rankins Pilkington Anders Glass Ltd Nichols & Clark Float Glass Ind. Promat Schott Vetrotech Saint- Gobain

Section 3 Fire-Resistant Glass

Glass Type (relevant EN product standard in brackets)	Fire-Resistance	Trade Name	Manufacturer/ main FRGG supplier ref Appendix A
Gel Laminated BS EN 12543	Integrity and Insulation	Paraflam Contraflam	CGI International Vetrotech Saint-Gobain
Thermally Toughened Borosilicate Safety (EN 13024)	Integrity	Pyran S	Schott
Thermally Toughened Alkaline Earth Silicate Safety Glass (EN 14321)	Integrity	Pyroswiss Extra	Vetrotech Saint-Gobain

Each glass type has its own characteristics, which can give rise to significant differences in fire behaviour.

Fire performance depends on the glass type and the fire-resistant glazed system design and construction. Also, the approved fenestration layout and glass pane sizes generally vary according to the particular approved glazed system being considered.

Performance in the event of fire

The table below provides a general description of the performance of various types of glass offered by GGF members.

Table 3: Glass Types and performance in fire

Glass Type	Trade Name Examples	Method of Providing Fire-Resistance
Wired	Pyrostem (safety) Pyroshield 2 Texture Pyroshield 2 Safety Clear	Due to thermal stress the glass breaks early on in the fire but is securely held together and in place by the integral wire mesh. The integrity limit is generally reached when the glass reaches its softening point and pulls out of the glazing pocket or if cracks open within the panes.
Ceramic	Firelite Firelite Plus Keralite FR	Due to its composition and micro crystalline structure this glass type has a near zero thermal expansion coefficient. The glass remains intact and performance is not edge cover dependant. This glass also has a very high softening point so its integrity limit is not normally reached. Firelite Plus is a laminated version based on an impact laminate interlayer, for impact safety rated applications.

Section 3

Fire-Resistant Glass

Glass Type	Trade Name Examples	Method of Providing Fire-Resistance
Heat Soaked Thermally Toughened Modified Soda Lime Silicate Safety	Vetroflam Pyroswiss	Relatively high toughening stresses in the glass are intended to retain integrity on exposure to fire, but edge cover and edge clearance requirements are critical to avoid failure. The integrity limit is reached when the glass reaches its softening point and pulls out of the glazing pocket, or if the glass shatters prematurely.
Modified Toughened Soda Lime Silicate Safety	Pyrocet Pyrocet XP (S), (T), (R) Pyrosec Tempaflam Fireswiss	The toughening process develops high stresses and these retain the integrity of the glass on exposure to fire. Edge cover, edge clearance and edge quality are critical to the performance of this product. The integrity limit of this glass is reached when the glass reaches its softening point and falls out of the glazing pocket or due to thermal stress, the glass shatters.
Resin and PVB Laminated	Pyroguard Wired Pyroguard Clear Pyroswiss Stadip Vetroflam Stadip	The integrity of these types of glass is achieved through the use of a resin-based interlayer formulated to have resistance against fire and flaming. In a fire, the glass layers crack and the interlayer carbonizes to give an opaque layer, which holds the glass together and reduces heat radiation. Its integrity limit is reached when the interlayer breaks down and/or the glass layers develop open cracks.
Laminated Intumescent	Pyrobelite Pyrobel Pyrostop Pyrodur Pyrodur Plus Contraflam Contraflam Lite Fireswiss Foam System Glass Pyranova	These types of glass have a sodium silicate-based interlayer formulated to turn opaque and swell on exposure to fire and provide a known level of insulation. The glass layers crack but are bonded together by the interlayer. The performance limit is reached when the interlayer breaks down, and this progresses as each interlayer intumesces. The products are based on a glass interlayer sandwich structure. This allows a wide fire performance range to be achieved by building up the structure based on alternate sheets of glass and interlayer.
Gel Laminated	Paraflam Contraflam	These products are composed of gel-filled double or multiple-glazed units using toughened glass. The gel is formulated to release water on exposure to fire to provide a known level of insulation. The integrity and insulation limit is reached when the interlayer breaks down and/or the glass shatters. The performance range is achieved by varying the thickness of the gel.

Section 3

Fire-Resistant Glass

Glass Type	Trade Name Examples	Method of Providing Fire-Resistance
Thermally Toughened Borosilicate Safety	Pyran S	On exposure to fire, the glass remains intact due primarily to its composition and low thermal expansion. Manufacturer's specified edge cover requirements must be complied with, but this type is much less sensitive to edge cover requirements than modified toughened soda lime glass. The integrity limit is reached when the glass passes its softening point and pulls out of the glazing "pocket".
Thermally Toughened Alkaline Earth Silicate Safety	Pyroswiss Extra	When thermally toughened, Alkaline Earth Silicate Glass has a higher temperature resistance than toughened float glass. In the case of fire, a high temperature differential develops between the glass and frame which causes differential expansion of the glass. This differential expansion results in additional stresses within the glass which would cause normal glass to break.

Fire-Resistant insulating glass units

Insulating glass units (IGUs) do not offer fire-resistance unless they incorporate one or more of the types of fire-resistant glass shown in Table 2 and have been fire performance tested.

Important considerations are that:

- The IGU must have its own fire test or assessment report based on test evidence
- It must be possible to confirm the direction of use before installation
- The components used in the IGU must be proven by test or assessment the fire-resistant glazing system must be appropriate for the application of the IGU, e.g. drained and ventilated for use in external façade applications

In all cases, the manufacturer/supplier must be consulted for evidence in support of the fire-resistant glazed system. Special glass units containing integral Venetian blinds may also be available fire rated.

Horizontal and sloped glazing systems

Fire-resistant glazed systems are most often used in a vertical orientation. However, there are some specialist approvals available for application in the sloped and horizontal orientations, including fire-resistant floor constructions.

A number of manufacturers have tested and approved systems available. These structures must also be able to take the imposed loads defined in BS 6399-1, Loading for buildings - Code of practice for

Best Practice Rule No. 4

Never assume that a vertical fire-resistant glazing system can be used either horizontally or inclined.

Section 3

Fire-Resistant Glass

dead and imposed loads.

Specific details must be obtained directly from the manufacturer/supplier of the system.

Decorative treatments on glass

It must not be assumed that decorative effects can be applied to all types of fire-resistant glass without affecting fire-resistance. Some types of glass may be decorated with surface treatments, e.g. sandblasting, screen printing, without impairing their fire-resistance performance. Others cannot be surface treated.

In all cases, the specialist advice of the manufacturer/supplier must be obtained to ensure that the proposed treatment is appropriate and that relevant evidence of performance is available.

Combining other performance requirements with fire-resisting glazing

Other performance requirements may be readily integrated within the fire-resistant glazing system specification without compromising fire-resistance performance. This is an increasing requirement as buildings become more complex and the building environment more demanding. This can include a range of different functions (e.g. thermal insulation, safety and security, decoration and privacy).

Because of their use in escape and access routes, impact safety and manifestation (i.e. to minimise the risk of people inadvertently walking into a glass partition) are particularly important additional performance requirements.

Summary of additional functions that may be combined with fire-resistance

- Impact safety, reference BS 6262 and EN 12600 (see Appendix B)
- Containment (or barrier loading), reference Building Regulations Approved Document K (Protection from falling, collision and impact : 1998, amended 2000)
- Thermal insulation - low emissivity energy saving and insulating glass units, reference Building Regulations Approved Document L1 and L2 (Conservation of fuel and power : 2010)
- Solar control
- Manifestation (see Appendix C)
- Privacy (e.g. blinds etc.)
- Acoustic (sound) insulation
- Decorative, pattern and colour effects
- Resistance against forced entry **
- Explosion and bullet protection **

** (only available with specialist glass and framing constructions)

For details of the additional functions that can be provided with fire-resistant glass, please check with the manufacturer or supplier.

Section 4

Fire-Resistant Glazing Seals

Section Contents:

- Importance of the glazing seal
- Function of the seal
- Available forms of seals
- Intumescent seal types
- Non-intumescent seal types
- Seal combinations with different glass types

Best Practice Rule No. 5

Standard non-fire rated glazing seals must **not** be used in fire-resistant glazing systems. **ALWAYS** use seals that have the appropriate evidence of fire performance.

Importance of the glazing seal

Glazing seals play an important role in fire-resistant glazed systems. They are an essential part of the system, and selection of the appropriate glazing seal is influential in ensuring that the performance capability of the full assembly is achieved under fire conditions.

An incorrect choice of seal may cause premature failure, particularly in some glazed system types. The seal must be capable of withstanding the temperatures experienced in fire without igniting, degrading catastrophically or losing strength and adhesion.

The following key rules apply:

- The seal must be compatible with the other system components, especially the fire-resistant glass
- There must be appropriate evidence of fire performance of the glazed system in all cases
- One seal must not be substituted for another without such appropriate evidence.

Suitable seals can be either intumescent or non-intumescent based and they are available in a variety of forms.

Function of the glazing seal

The combined functions of the glazing seal as follows:

- Bedding the glass against the retaining bead and minimising the probability of uneven point loading or edge stresses (which can be critical for special toughened glasses, for example)
- Sealing the gap between the glass, the bead and the edge of the frame to prevent the penetration of hot gases and flame
- In the case of intumescent seal types, providing additional protection to the top of a timber bead to lower the risk of bead ignition - a benefit that comes at the expense of gap sealing performance, so both intumescent and non-intumescent seals have been developed for use with integrity-only glass types for both 30 and 60 minute applications.

Available forms of seals

A variety of different forms are available, as follows:

- Preformed rigid strips which are normally encapsulated with PVC for protection and decorative coloured effects

Section 4

Fire-Resistant Glazing Seals

- Self-adhesive preformed flexible strips available either in coils or cut to standard lengths
- Preformed rigid channels encapsulated by PVC, or preformed rubber channels, which are fitted around the outside edge of the fire-resistant glass as a gasket
- Mastic compounds available in cartridges, of modest expansion which must be applied strictly according to the manufacturer's recommended thickness
- Fibre gaskets or woven tapes of mineral fibre
- Encapsulated cellular seal foam strip, for specialist applications only with only certain glass types and only when clearly specified.

Intumescent seal types (see summary in Table 4)

Intumescent seals are based on materials that expand and foam on exposure to heat. The degree of intumescence and the expansion pressure vary according to the material and its formulation. In particular, the following should be noted:

- Sodium silicate and graphite based materials may have a high expansion pressure which means they have to be used and applied carefully as the application of too much material may push the beads off, leading to premature failure
- Ammonium phosphate materials do not show expansion pressure to the same degree, but if the expansion is too great then the density of the material left in the gap between the glass and the bead may be too low to inhibit erosion leading to premature failure
- Preformed strips of intumescent compound which ensure that the correct thickness and amount of material is applied.

Intumescent seal strip materials may be unprotected if they are composed of a material that is not particularly sensitive to moisture and they will generally have a self-adhesive layer to fix to the bead.

Table 4: Summary of intumescent seal types

Seal Material	Trade Name/ Manufacturer	Type	Method of providing Fire-Resistance
Sodium Silicate	Pyroglaze Mann McGowan	Liner	Hydrated sodium silicate has been used for many years as an intumescent material. It activates on exposure to heat (at 100°C) and generates a high pressure on expansion, which tends to be unidirectional, forming relatively rigid foam. Once rigid, sodium silicate does not allow further movement and the pressure generated can therefore be helpful in restraining movement of other components in the system, keeping adjacent components in place.
	System 90 Plus Lorient	Channel	
	System 90 Plus Lorient	Liner	

Section 4

Fire-Resistant Glazing Seals

Seal Material	Trade Name/ Manufacturer	Type	Method of providing Fire-Resistance
Ammonium Phosphate	Fireglaze G30 Sealmaster	Strip	Ammonium phosphate based products are complex formulations which produce an open structure when heated to around 180°C. They usually contain fire retardants and some versions need external protection against water vapour. They generate very low pressures on expansion which is usually multidirectional. They have some flexibility when expanded, which can be used to accommodate some movement of other components.
	Firestrip 30 Hodgson	Strip	
	Pyrostrip 300 Mann McGowan	Strip	
Graphite	Pyroglaze 30 Mann McGowan	Strip	Intercalated graphite is usually held in a binder to form a strip product. It activates at around 200°C but is not affected by moisture. Graphite expands considerably and generates a high pressure if contained when heated. Products containing intercalated graphite may expand uni or multi-directional depending on the product type. Also the degree of expansion and hence the pressure, depends on the amount and type of graphite in the product. If contained on expansion, it forms a dense product, otherwise it is a light, low density material.
	Pyroglaze 60 Mann McGowan	Strip	
	Pyroglaze FGSA Mann McGowan	Strip	
	Pyroglaze Liner Mann McGowan	Strip	
	Flexible Figure 1 Lorient	Strip	

Non-intumescent seal types (see summary in Table 5)

These seal types are composed of materials that are either non-reactive when exposed to heat (such as mineral fibre products) or those which show only minimal or modest expansion. Because of this, the following should be noted:

- Non-intumescent seals may not perform satisfactorily if the shrinkage of the timber bead is too great, because the seal is unable to expand to fill the gap created by this shrinkage
- The permeability of uncoated mineral fibre seals means that they are generally acceptable for use with metal framing systems and insulation glass types in general, but may be unsatisfactory in timber systems with

Section 4

Fire-Resistant Glazing Seals

Table 5: Summary of non-intumescent seal types

Seal Material	Trade Name/ Manufacturer	Type	Method of providing Fire-Resistance
Mineral or Ceramic Fibre	Fireglaze 2000 Sealmaster	Strip	<p>Gaskets made from mineral fibres are not affected by the heat of the fire but their permeability and insulation properties depend on the degree of compression or whether they are coated. Uncoated fibre gaskets are usually used with metal frames where their compressibility is an advantage, and where their inability to expand is not a problem. Uncoated fibre gaskets are not normally used on their own with timber beads in conjunction with integrity-only rated glass (and must not be so used without appropriate evidence of performance) but coated gaskets combined with other products can give an excellent performance. The performance may also be enhanced using special high temperature adhesive to bond the material to the glass and bead in order to reduce the tendency of non-laminated integrity glass to slump at longer times (e.g. in some cases for 60 minutes and longer).</p> <p>Incompressible ceramic fibre woven fibre tape, available in various thicknesses, is suitable for use in 30 minute steel frame integrity glazed systems, and may also be used with high temperature ceramic adhesives for longer periods of fire-resistance (in some cases for 60 minutes and longer).</p>
	Firetape Hodgson	Strip	
	Pyrotape Mann McGowan	Strip	
Elastomeric Gasket	Pyroglaze Channel Mann McGowan	Channel	<p>These products have been used for some years normally for 30 minute applications. They need a fire retardant to prevent the elastomer from burning on the non-fire side.</p>
	System 36 Lorient	Channel	
	System 360 Lorient	Channel	
Ablative Seals	Intuglaze Hodgson	Mastic	<p>These products are often produced in cartridges for easy application but may also be preformed strips with a removable backing strip on application. They may have a little expansion to cope with the shrinkage of the timber bead but this is normally much less than for a typical intumescent sealant. A fire retardant is normally required to prevent ignition. In the case of cartridge applied compound it is important that the manufacturer's instructions are followed in respect of the thickness of compound between the bead and the glass. Usually between 2mm and 4mm is required for 30 minute applications but more may be needed for longer time periods.</p>
	Fireglaze Compound Sealmaster	Mastic	
	Fireglaze Sealmaster	Mastic	

Section 4

Fire-Resistant Glazing Seals

Seal combinations with different glass types

The most onerous applications are for modified toughened soda-lime-silicate glass because these glass types can only tolerate a small edge cover (10mm maximum) due to the dangers of thermal shock or stress. This is less of a problem with steel or aluminium systems compared with timber systems but it is particularly acute for larger panes in timber frames, although there have been some successful tests in timber for 30 minute applications. In view of such factors, great care must be taken to make sure that the correct seal is used in conjunction with modified toughened glass.

In timber frames, both insulation and partial insulation glass types perform well because the surface of the non-fire side immediately adjacent to the glass is protected against direct radiant heat for the period that insulation is maintained. These glass types are able to function with most types of seals for 30 minute applications. Applications for 60 minutes may still be a problem, however, if the seal does not prevent flame penetration around the glass edge between the timber bead and the glazing aperture in the case of doors, or between the bead and the frame in the glazing rebate for screens.

For 60 minute applications it is necessary to consider carefully the various approved applications provided by the seal manufacturers. Some products have been tested in fully glazed doors (e.g. pattern 10) for 60 minutes whilst others may only have approval in small panes.

Glazing for 60 minute applications using timber beads is much more difficult than for 30 minutes, and individual seal manufacturers must be consulted to establish the range of their test evidence. The importance of this cannot be overemphasised because, whilst some glass products work exceptionally well with some seal systems, it cannot be assumed that all combinations work in the same way.

For 60 minutes performance in timber, a lining strip is normally fitted around the whole glazing aperture rebate under the beads. The purpose of this lining is to prevent failures from occurring as a result of fissures in the beads lining up with fissures in the door core or frame. Any holes from the inside of the assembly through to the outside result in immediate failure.

There are third-party accreditation schemes available for glazed systems which help to ensure that there is compatibility between glass and seal, that seal manufacturers claims are reliable and that their products perform consistently. An example of this is the BWF-CERTIFIRE scheme.

Note:

The glass, glazing seal, retaining bead and its fixings all work together as a glazed system. Individual components must not be changed without checking that the performance of the system is unaffected. Appropriate evidence of performance must always be provided.

Section 5

Timber Screens and Doors

Section Contents:

- Behaviour of timber in fire
- Timber density
- Particular considerations concerning timber fire doors
- Timber glazing beads
- Additional information concerning glazing beads used in timber fire doors
- Bead fixings
- Setting blocks
- Integrity and insulation glazing with timber fire-resistant systems
- Glazing apertures in doors
- Linings for glazing apertures
 - ♦ Particular considerations to achieve 60 minutes integrity performance in timber glazing systems
- Particular considerations for 60 minute fire doors
- Fanlights

Behaviour of timber in fire

Timber chars and possibly flames under fire conditions at a rate and to an extent of deterioration that depends on a number of interacting factors:

- The intensity of exposure to radiant heat flux or flame
- The time of continuous exposure
- The density, grain structure and moisture content of the timber

As a general rule for fire safety designers, non-piloted ignition (“spontaneous” or “auto ignition”) does not generally occur unless radiant heat intensities reach the range 25kW/m² to 33kW/m². Under piloted (i.e. naked flame) ignition, flaming can occur at lower intensities of 12kW/m² to 13kW/m².

As timber shows limited expansion in a fire, timber screens and doors generally do not induce significant mechanical stresses in adjacent constructions.

Both 30 and 60 minute timber systems therefore need to be carefully designed because of this degradation. The type of timber, section thicknesses, fixings, and bead shapes all have to be specified in detail. Where 60 minute timber fire screens and doors are required, additional detailing will be needed because of the increased fire exposure time.

Timber density

The type of timber and its density is a key factor which determines the rate at which timber chars and degrades under fire conditions. The grain density and straightness of the grain also exert an effect in terms of the degree to which twisting may occur in the event of fire.

Timber is a naturally occurring material and a certain amount of natural variation in properties, especially density, can occur.

Section 5

Timber Screens and Doors

The following information can be taken as general guidance for the charring rates of timber:

- Hardwood timbers used in fire-resistant glazed systems, generally have densities more than 630 kg/m^3 , with typical char rates in the order of 0.5mm per minute e.g. Sapele, Iroko or Dark Red Meranti – note exceptions below
- Softwood timbers used in fire-resistant glazed systems generally have densities more than 480 kg/m^3 , with typical char rates of around 0.7mm per minute e.g. European Redwood.

However, there are some exceptions:

- Certain temperate-zone hardwoods e.g. Ash, demonstrate burning characteristics closer to those found for softwood timbers. These types of hardwood must therefore be designed with thicker frames and beads to take into account the increased charring rate. Fire test evidence or third party assessments should be referred to prior to specifying timber species, to ensure performance.
- Some softwoods e.g. Douglas Fir, with densities lower than 480 kg/m^3 which char faster than 0.7mm per minute must therefore be used in

Key factors determining the performance of timber glazing systems

- Type of glass: Integrity only, Partial or Fully Insulating
- Type and density of timber
- Size of sections and cross-section dimensions of frame
- Depth of glazing rebate
- Size, shape and design of glazing beads
- Type of fixings of the beads, their location and angle of fixing relative to the type of glass
- Edge cover and clearances for the different types of fire-resisting glass (especially for modified soda-lime silicate toughened glass)
- Type of glazing seal
- Nature of any timber treatment required
- Compatibility of all components
- Method and materials used to fix the frame to the surrounding structure, e.g. walls
- Fire stopping between the fire-resistant screen or door frame and wall
- Internal or external position
- Requirements for doors within screens
- Availability of fire test or third party assessment evidence to support detailed specification
- Installers capability regarding fire-resistant glazing and availability of trained and certified personnel

Section 5

Timber Screens and Doors

larger sections to achieve the required fire-resistance period – see note above

Particular considerations concerning timber fire doors

A timber fire door is a carefully designed and engineered product that has far more to do than simply filling a hole in a wall or partition (see diagram 4).

Fire doors are fundamental to the escape and access strategy for fire safety in buildings, and they have to function correctly as a fire barrier. It should be noted the size, position and aspect ratio of the glass is critical. Fire test evidence or third party assessments must be submitted to support the glazing specification.

A fire door comprises the door leaf, door frame, hinges, associated ironmongery, intumescent fire and cold smoke seals and the glazing system in any vision panels. These components must all work together to ensure that the completed door assembly functions correctly in the event of a fire.

To ensure the fire performance of the door is achieved, the manufacturer's instructions concerning assembly and installation must be correctly followed.

As a general guide, door thicknesses are generally at least 44mm for 30 minute ratings and 54mm for 60 minutes. The individual components of a door assembly must not be changed from those specified within the fire test report. Check substitution under Certifire and Chiltern test certification.

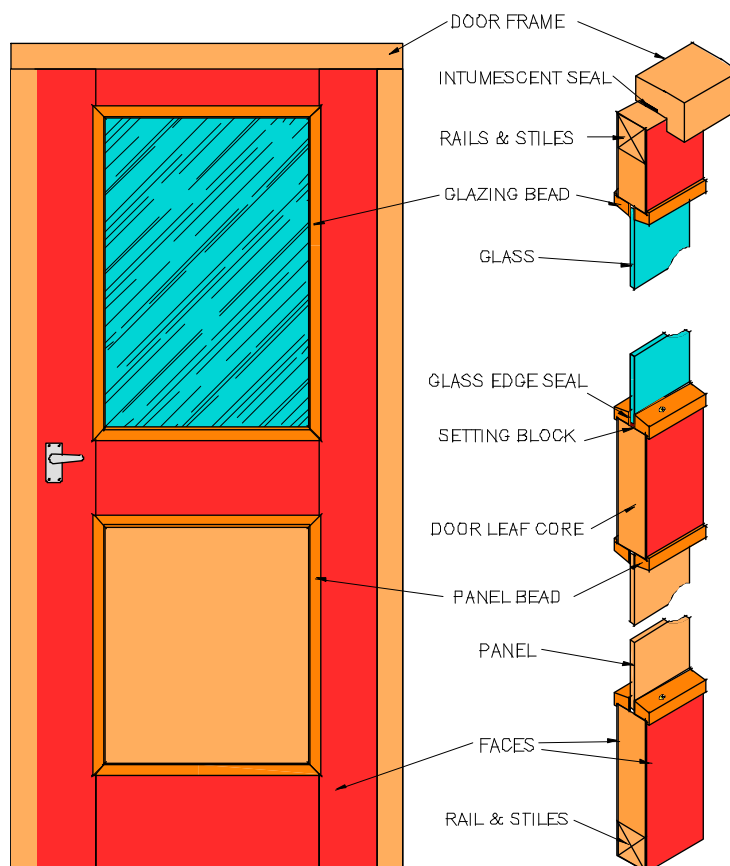

Diagram 4 – Example of 30 minute timber glazed door

Section 5

Timber Screens and Doors

Additional factors influencing fire-resistance performance

Door Leaf

- Single leaf or double leaf, single action or double action, latched or unlatched
- Thickness and construction, i.e. core material, sub-facings, facings and lippings
- Type of timber and nature of any timber-based products that may have been used
- Width and height of door leaf

Glazing Aperture

- Size and shape of aperture
- Unless tested, the glazing aperture must not cut through internal stiffening elements within the door
- Location of glazing aperture, especially relative to door edge perimeter
- The distance between apertures
- The layout of multiple apertures
- Preparation and “finish” of any apertures, especially corners
- Methods and materials used to line the aperture

Glazing System

- Size and section of glazing beads
- Trimming and jointing of glazing beads
- Glazing materials, i.e. intumescent glazing seals, liner etc
- Position of, length and direction of fixings (screws/pins)

General

- Proper application of smoke seals if appropriate
- Door furniture: hardware, such as closers, latches and hinges and their suitability for use in fire doors
- Door frame and support structure
- Surface finishes and treatments
- The intumescent sealing system in the door leaf, door frame, ironmongery protection and frame to structure gaps

Section 5

Timber Screens and Doors

Timber glazing beads

The glazing beads are the smallest section of timber in a fire-resistant glazed system, and therefore the species of timber used for the bead, the bead thickness, bead shape, size and method of fixing are all critically important in achieving the required fire-resistance performance. This is particularly important for integrity-only glazed systems.

The bead section size and shape should both be sufficient to ensure that there is enough residual timber remaining at the end of the fire-resistance period to ensure integrity of the glazed aperture and to prevent failure of the screen or door. Fire test or third party assessment evidence should be consulted when determining the bead specification.

When a clear integrity-only (non-insulation) glass type is used then there is a risk of bead ignition on the unexposed face due to transmitted radiant heat. A traditional design feature to reduce this risk is to chamfer the top of the bead (instead of having a square bead) to minimise the exposed surface area and the radiant heat intensity on the top of the bead. Test evidence is required for the glass type, bead detail and glazing sealant combination. Such approved glazed systems are available, and the door/screen manufacturer/supplier must be contacted for specific details. The top of a timber bead may be successfully protected by using an insulation rated fire-resistant glass or possibly a partial insulation (EW) fire-resistant glass.

Note:

- **If the bead or their fixings fail prematurely then the glass will fall out of its aperture**
- **The glazing pocket must be protected against leakage by hot gases from the exposed side, which could penetrate around the glass edge and scour out the glazing pocket**
- **For a non-intumescent integrity-only glass, the use of an appropriate intumescent glazing material helps to seal any gaps that develop between the glass and the bead**
- **An intumescent glazing seal may also swell sufficiently to mask or protect the face and top of the bead from radiant heat (see Section 4)**
- **Laminated integrity-only fire-resistant glass types that reduce the transmitted radiant heat (i.e. EW class) provide a greater margin of safety by minimising the risk of bead ignition on the unexposed side**
- **Insulation with integrity glasses (i.e. EI class) significantly reduce the risk of bead ignition by preventing significant heat transfer to the non-fire face by radiation**
- **Glazing rebates formed from the solid should always have identical mechanical fixings as the removable beads**

Section 5

Timber Screens and Doors

Examples of timber bead types and intumescent seals

Timber beads used in fire-resistant glass doors and screens can be of various designs and can be used with different intumescent seal systems.

Timber screens and doors may be manufactured with either flat glazing platforms or rebated glazing platforms. Diagram 5a shows flat glazing platform options and diagram 5b shows rebated glazing platform options.

The following show the more common types and the combinations allowed will be shown in the appropriate test/assessment report.

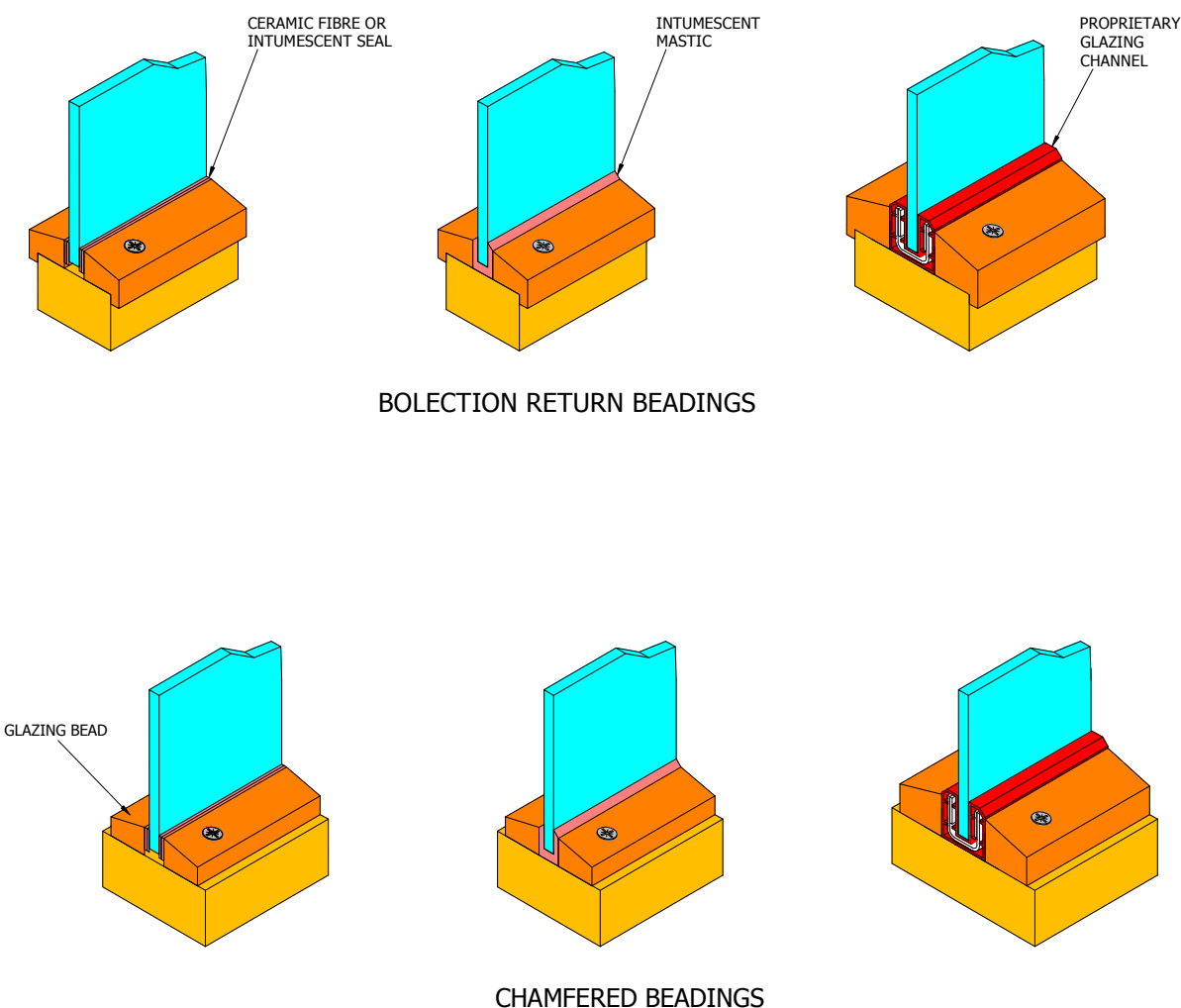
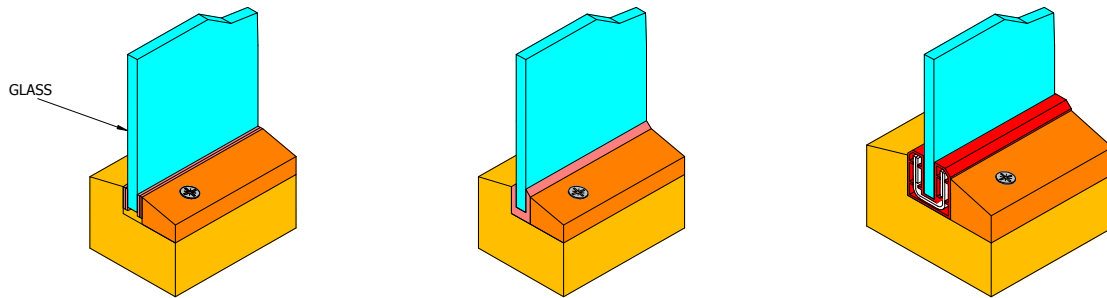

Diagram 5a – Examples of different types of bead used with flat glazing platform

Section 5

Timber Screens and Doors



CHAMFERED BEADING WITH REBATED FRAME

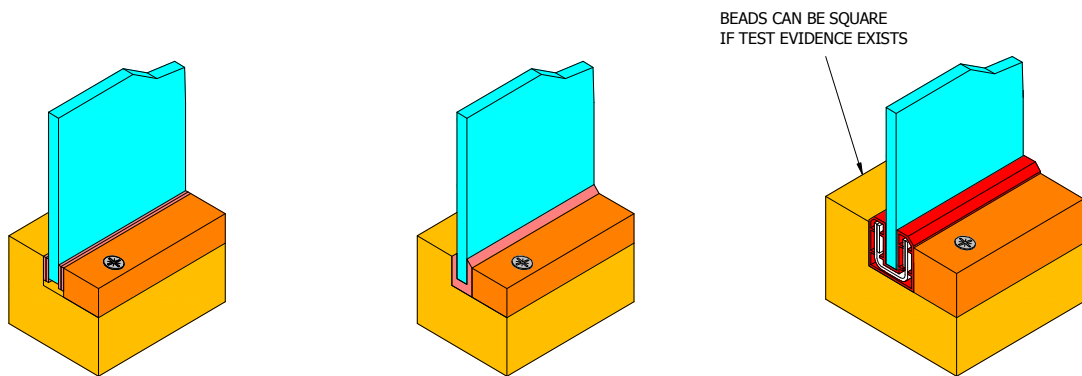

SQUARE BEADING WITH REBATED FRAME

Diagram 5b – Examples of different types of bead used with rebated glazing platform

Section 5

Timber Screens and Doors

Additional information concerning glazing beads used in timber fire doors

Beads used for fire doors require additional considerations to those used for screens in view of the door leaf construction:

- The glazing beads may need to be a higher density than that used in the main door construction.
- Circular apertures in fire doors may need a steeper splayed chamfer than normally used for rectangular

Bead fixings

The bead fixings are critical to the successful performance of a fire-resistant timber glazed system.

The function of the bead fixings is to keep the glass in place in the frame should the beads burn away.

The following factors are key to the successful performance of the system:

- Screws, nails or pins may be used, provided that the material and gauge is sufficient to give the required fire-resistance performance when tested
- The fixings must be angled towards the centre of the frame (and not vertical)
- The length of the fixings should be sufficient to ensure sufficient penetration into the sub-frame to give a secure fixing (typically at least 38mm for 30 minute performance and at least 50mm for 60 minutes)
- Particular care must be taken if air gun pins are used, to ensure that the supplied evidence supports the use of these components, as pin gauge and angle of application are particularly critical for this fixing type
- The distance between the fixings must be as shown in the supporting evidence (fixing centres typically start at a maximum 50mm from the aperture corner and there after are spaced with a maximum separation of 150mm)
- It is good practice to stagger fixings on each side of the glass to ensure fixings are not directly opposite each other and prevent fixings for interfering with those on the other side
- The frame must be sufficiently robust to secure the fixings in the event of fire (particularly relevant for timber doors)

Best Practice Rule No. 6

When glazing fire-resistant Toughened Soda Lime Silicate glass into timber take particular care to ensure that edge cover stipulations from the manufacturer/supplier are complied with and that the glazing seal is exactly as specified.

Setting blocks

The supplier's recommendations concerning the type of material, thickness, location and positioning of the blocks must be followed for the particular glazing system being installed.

Setting blocks are required to locate the glass correctly in the glazing aperture so that fitting tolerances and expansion allowances can be accommodated. The type of block must be specified.

Section 5

Timber Screens and Doors

In the case of timber doors, the use of setting blocks leaves a gap between the edge of the glass and the internal base of the cut out which may not be sufficiently sealed by beads or glazing seal strips. This may be acceptable subject to fire test evidence. Where hot or cold sealing is also required, then special attention to this aspect of design will have to be followed. It is very likely that the gap will require sealing.

Best Practice Rule No. 7

Glazing blocks must always be used as directed, to ensure correct expansion provision, appropriate glass edge cover and positioning of the fire-resistant glass within the frame.

Integrity and insulation glazing with timber fire-resistant systems

Using an integrity and insulation rated glass significantly reduces the possibility of bead ignition and therefore the detailing of the bead is much less significant in terms of overall fire performance compared with the requirements for integrity glass. The use of chamfered beads with these glass types is no longer a concern. The use of any shaped or moulded beads, for reasons of style and design, are possible provided there is suitable fire test evidence.

However, attention to the fixings of the beads and their location is still very important in order to keep the glass in its aperture.

When using insulating glass, especially for 60 minute fire resistance, the design of the frame section must be able to support the additional weight of the glass compared with integrity only glasses. The design must also take into account the reduction in timber strength that will occur due to the charring of the timber during the fire.

Note: UK Building Regulations require doors to have a smoke control function in certain locations, designated with an "S"

e.g. FD30S = 30 minutes integrity fire door with smoke control

Best Practice Rule No. 8

Glazed panels must only be installed in doors which are appropriately tested. Glazing apertures must never be cut in doors that are not designed to take such apertures.

Glazing apertures in doors

The cutting of an aperture within a door leaf can weaken its core by removing some key structural components. This can severely prejudice fire performance.

Therefore:

- The original door design template must include the provision for glazed apertures of the type, layout and shape being considered
- Apertures must be formed as part of the door manufacturing process under factory controlled conditions according to manufacturer's instructions (and not cut out at a later stage as a secondary operation on a completed assembly or on site)
- Modular glazing kits may only be used if this is approved with the door design

Section 5

Timber Screens and Doors

- For 30 minute doorsets, glazing of the aperture may be conducted on-site using the correct materials and specification according to the supplied evidence
- For fire-resistance periods of 60 minutes, or longer, it is recommended that the doors be purchased complete, i.e. factory-glazed
- For rectangular apertures, any glazing gaskets must be properly mitred at the corners in line with manufacturer's instructions
- Rectangular apertures must not be replaced by circular or non-rectangular apertures of the same area without test or assessment evidence
- The glazing seal for any curved or circular apertures must be capable of being formed to fit the required curvature without splitting. This is particularly relevant when using pre-formed channel type gaskets but is less of a problem when strip type gaskets are used as these are flexible and can, if necessary, be easily butt-jointed below the bead line
- Similarly, a hardwood lining fitted in straight lengths will have to be replaced by an alternative method for curved cut outs

A particular door leaf design will have a maximum permissible size of glazing aperture based on full-scale test evidence on that specific door construction.

It must not be assumed that this maximum approved size may be automatically applied to another door leaf construction. Each door assembly requires its own specific test evidence, or assessment evidence related to test data. This also applies to glazed screens.

Multiple apertures are only allowed if the door assembly under consideration has the appropriate test or assessment evidence.

Linings for glazed apertures in timber doors

Protective lining of the glazing cut out will be necessary for those door leaf constructions using low density core material, if either or both:

- The core material is not able to secure the glazing bead or glazing channel fixing sufficiently securely in the event of fire
- The unprotected exposed core material does not have sufficient resistance to erosion by fire once the beads have burnt away

Any lining that is used must be located tightly into aperture corners.

When fire erosion is a potential problem, then a hardwood lining of satisfactory material is usually required. This will normally be a minimum of 6 - 8mm thick and a minimum density of 630 kg/m³. These linings are usually essential for 60 minute

Best Practice Rule No. 9

Test evidence for glazed apertures in screens or steel doors is not appropriate to substantiate performance in a timber door.

Section 5

Timber Screens and Doors

and above fire-resistance.

It may be acceptable for aesthetic reasons to use solid timber linings that are visible on the front of the door. In these situations, special concealed linings may be used. These are usually built-in during the manufacturing process. Confirmation

Particular considerations to achieve 60 minute integrity performance in glazing systems

At 60 minutes fire exposure, the glazed system will have seen significantly higher temperature and radiant heat intensities when compared with 30 minutes fire exposure. Additional factors have therefore to be taken into account in designing these systems:

- Larger sections and more secure fixings at closer centres are needed to compensate the accelerated and more extensive fire erosion of the timber sections
- Different types of seals are required to minimise the possibility (in particular) of soda-lime silicate glass types slumping out of the frame or door aperture
- An intumescent rebate liner is necessary to reduce the passage of hot gases around the glass edges due to erosion of the beads, and prevent undercutting of the glass in the glazing pocket
- The use of a laminated integrity glass with an enhanced performance in reducing radiant heat (partial insulation or EW types) or a fully insulating glass type to eliminate the risk of flaming of the beads on the unexposed side

The purpose of an aperture rebate lining material is to prevent failures from occurring as a result of fissures in the beads fortuitously lining up with fissures in the door core or frame. Any holes from the inside of the specimen to the outside would result in immediate failure.

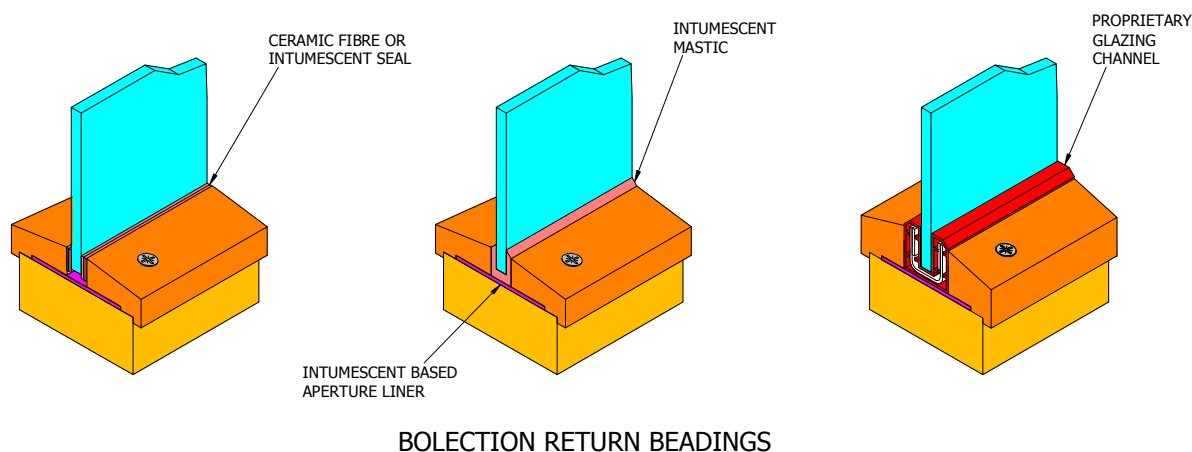

Diagram 6 – Examples of 60 minute timber framing details

Section 5

Timber Screens and Doors

Note:

The width of beads used to glaze modified toughened soda-lime silicate fire-resistant glass types can be increased but, the height must not exceed any stipulated edge cover plus tolerance requirements, normally a maximum of 10mm + tolerance.

Particular considerations for 60 minute fire doors (FD(S)60)

The achievement of a 60 minute (or greater) fire-resistance performance requires particular attention to detail in the door structure, materials, and the glazing system design and components.

Intumescent or non-combustible ceramic fibre liners are usually necessary for apertures, in addition to any timber liner that is normally required.

The function of such liners is to inhibit the permeation of hot gases, volatiles or flames through the door leaf, or around the glazing system, to the non-exposed face. Erosion of the exposed face as a result of such permeation could char timber beads and undermine the glazed system's intumescent seal.

This is required to prevent integrity failure, even though the glass and its glazing system may be retained in place (see Section 4).

Fanlights

Fanlights are glass apertures that are located directly above a door. This type of glazing is usually incorporated within the door assembly by extending the door frame height and building in a transom. The transom acts as both a door frame head to locate the top edge of the door leaf and as a bottom supporting element for the fanlight glazing arrangement.

Note: Fire test or third party assessment evidence must be available to cover fanlights.

System Name or Trade name	Fire Resistance Integrity/Insulation	Additional Comments	Manufacturer
Pyrovista	30/0	Glazed Screens	Mann McGowan
	30/30		
	60/30		
	60/30		
Firestile	30/0	Fully Glazed Fire Doors	Mann McGowan
	30/30		
Clear Run	EI30	Butt Jointed Timber Screen	C3S Securiglass
	EI60		

Table 6 - System and Trade names of fire-resistant timber screens and doors

Section 6

Metal Systems for Screens and Doors

Section Contents:

- Behaviour of metal in fire
- Metal screen
- Metal fire doors
- Beads and fixings
- Installation
- Edge cover requirements
- Key factors affecting performance
- Pressure glazed systems
- Glazing seals for metal framed systems
- Frames for external applications (drained and ventilated systems)
- Curtain walling systems

Behaviour of metal in fire

Unlike timber, metal frames expand when heated which can lead to flexing and twisting of the frame. This means that provision for thermal expansion is particularly important. For example, at 700°C, a 3m length of steel section will expand in length by about 25mm. If constrained, this would give a bow at mid-distance of approximately 150mm.

The fixings of the framed assembly to the supporting structure are also important, taking into account expansion allowances.

Other factors that influence performance are thermal conductivity, oxidation, loss of strength and melting. Framing options based on both aluminium and steel are possible but fire-resistant frames must be specially designed to withstand fire conditions. Different framing constructions are used for aluminium and steel in view of their different thermal properties.

Metal frames must not therefore be used either for fire screens or fire doors unless suitable fire test evidence is available.

Metal framing for use in conjunction with fire-resistant glass falls into two categories:

Key factors determining the performance of metal glazed

- Type of metal
- Integrity only or integrity and insulation frame design
- Size of sections and cross-sectional dimensions of the frame
- Methods and materials used to fix the frame to the surrounding structure e.g. wall, floor etc.
- Fire stopping between the fire-resistant screen and the structure e.g. wall, floor etc.
- Depth of glazing rebate
- Type of fixings for the beads or other glass retaining mechanism
- Edge cover and edge clearance for the different types of fire-resistant glass
- Glazing seals
- Compatibility of all components

Section 6

Metal Systems for Screens and Doors

- Integrity only
- integrity and insulation

The fire-resistant glass must be positioned on non-combustible setting blocks, e.g. mineral fibre board, to ensure that the glass is fitted centrally within the opening or as specified to accommodate expansion and location requirements of the glass.

Metal screens

Steel

Framed systems are available from three main sources:

- Rolled formed steel profiles, available from proprietary systems manufacturers and fabricated by specialist metalwork fabricators
- Hot rolled steel sections, such as W20-type steel sections
- Standard steel sections, formed in many different configurations by individual manufacturers to their own specifications and proprietary designs.

Steel profiles are typically 2-3mm thick, and either hot-rolled or cold-formed from strip. Each system supplier or fabricator will have their own fire test evidence based on proprietary steel profile sections, giving the maximum pane size for each glass type, glazing material used, type of glazing bead and the spacing of the bead fixings.

Steel-framed glazing systems are capable of providing fire-resistance performance for both integrity-only or integrity and insulation and ratings from 30 minutes up to 120 minutes.

Over-clad steel systems are also available, containing steel as the main fire-resistant structural elements with aluminium, stainless steel or other capping material for appearance or style.

Aluminium

There are a number of proprietary fire resistant systems available from specialist suppliers and fabricators based on extruded aluminium profiles. The internal structure and make-up of these systems is specialised and dependent on the supplier's specific proprietary designs. Specialist installation techniques are also required.

Aluminium systems are therefore normally available only on a supply and fit basis and should only be used if suitable fire test evidence exists.

Composite systems

Such systems are produced from a combination of materials such as fire-resistant calcium silicate boards either side of a steel core with aluminium covers, or calcium silicate board with steel tubes on either side. But in all cases, only proprietary systems with the necessary evidence of performance must be used.

Best Practice Rule

No. 10

Integrity frames must not be used for insulation applications and all components must be compatible under fire conditions.

Section 6

Metal Systems for Screens and Doors

Timber and metal combinations behave differently when exposed to heat from a fire and therefore require special design expertise.

Metal fire doors

The whole door assembly, including the glazing and all associated components, must have relevant and applicable evidence of performance.

- A metal door must not automatically be assumed to be a fire-resistant door. It is not recommended that conventional metal doors be converted to fire doors. Only door systems specifically designed for fire-resistance may be used where fire-resistance is a requirement of the specification.
- When re-glazing an aperture in a fire door, the correct fire-resistance performance must be maintained and the glazing seal must be compatible with the glass. The full glazing system should be replaced exactly as originally specified.
- Care needs to be taken to ensure that critical elements of door hardware (such as door closers) are not positioned directly above integrity-only clear fire-resistant glass because of the risk of overheating due to both radiant and convection heat from such glass types. The main features of metal fire doors are summarised in Figure 7.

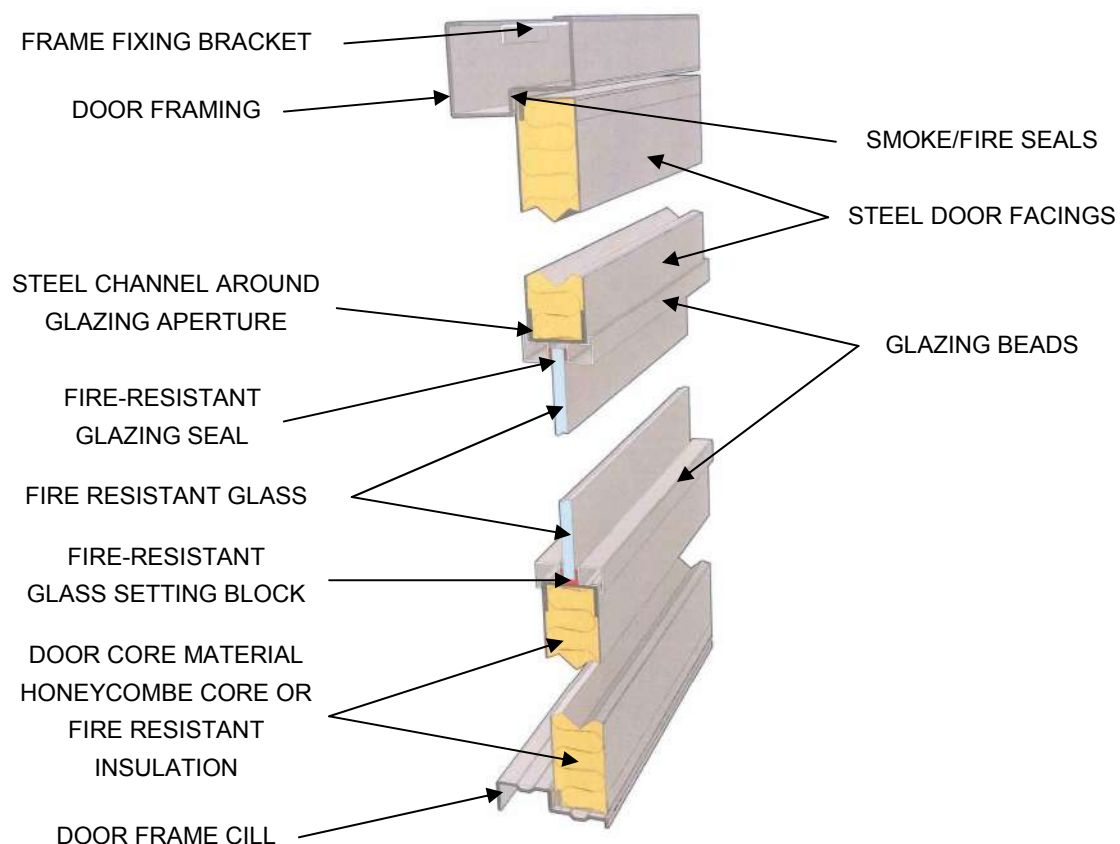

Diagram 7 – Example of the components of a fire-resistant steel glazed door

Section 6

Metal Systems for Screens and Doors

Beads and fixings

Glazing beads for metal systems are available in various forms such as angles, channels or box sections which can be fixed with screws, bolts or clips. There is also a range of specially formed channels available which fix over shaped studs. The most popular are snap on beads or locating beads.

Fixings generally offer a 20mm deep glazing rebate with the screws, bolts or self drill/screw studs spaced at approximately 250-300mm centres. Often metal beads may be cut short to allow for expansion and to maintain the fixing during fire.

The glass must be retained in one of two ways: either steel pressure plates or with a profiled metal glazing bead.

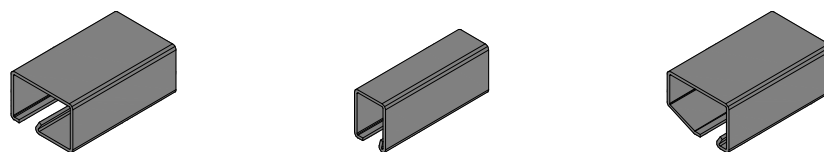
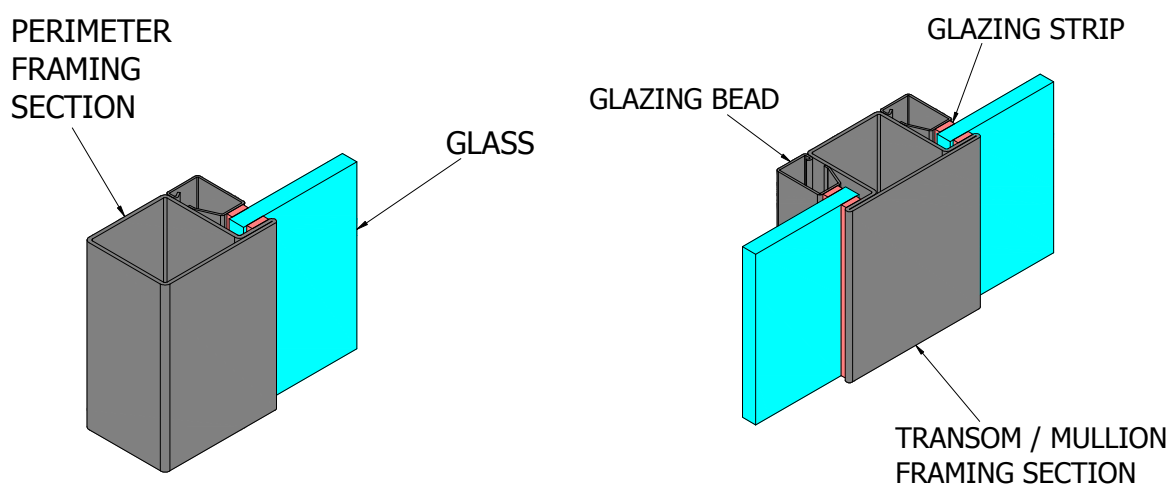

EXAMPLES OF STEEL BEAD SHAPES

Diagram 8 –Example of bead types used within steel frames

Section 6

Metal Systems for Screens and Doors

Installation

Fire-resistant metal screens and/or doors must be fitted into a suitably sized opening, with supporting structure, which achieves at least the same level of fire performance as the fire-resistant element. The frame and its fixings must also support the weight of the glass.

The approved fire-resistant assembly must be attached with fixings which are not affected by the heat of the fire.

Any gap between the frame and structure must be filled with suitable fire-resistant packing, e.g. compressible mineral fibre wool, which is generally covered with a silicone seal.

Careful consideration must be given to the detail such that the required thermal expansion for the full assembly is not inhibited.

Edge cover requirements

Most metal framed systems offer a 20mm deep glazing rebate which is adequate for the majority of fire-resistant glass types. For modified toughened soda-lime silicate fire-resistant glass, special consideration must be given to the specification for glass edge cover (generally 10mm maximum).

Glazed systems in applications where resistance against crowd pressure is a requirement should comply with the requirements of BS 6180, which requires a minimum edge cover for the glass of 15mm.

Note: Always follow the supplier's specific glazing instructions regarding any guidance, or limitations, on edge cover.

Key factors affecting performance

Integrity

Metal frames for integrity only ratings are relatively uncomplicated compared with insulating frames. They serve principally to retain the glass in position to prevent the penetration of flames and hot gases. An example is given in Figure 8.

Integrity only systems must be designed with bowing particularly in mind because of the temperature differential between the hot and cold sides of the frame which can cause bowing due to differential expansion (normally convex towards the fire side).

This may, for example, require the use of a flexible glazing seal to minimize and evenly distribute any edge stresses that result.

Similarly, expansion allowances must be provided as specified for the frame within the opening of the supporting construction. These requirements must be followed on installation.

Fire performances of 60 minutes and longer are commonly available, but normally require attention to the following:

- Bonding of the glass where necessary using high temperature non-combustible adhesives and ceramic fibre gaskets
- Measures to minimize heat transfer to the glass edges which could cause softening of the edges (which is not normally an issue for 30 minute metal glazed systems but certainly is at longer times for non-

Section 6

Metal Systems for Screens and Doors

- intumescent glass types).
- Design detailing to apply mechanical restraint to the glass edge, for example, through glazing pressures

The thermal conductivity of metals tends to give a better chance of successful performance for modified toughened soda-lime silicate glass types in integrity-only frames compared with performance in an insulation (metal or timber) framing system. This is due to the relatively better chance of achieving lower thermal gradients between the glass edge and centre, giving rise to lower thermal stress towards the glass edge.

Insulation

Special constructions are needed to achieve insulation performance. Each system company has its own system design based on special metal profiles. The details of system design and construction are critical in achieving adequate fire resistance.

One way of achieving this is by using internal blocks of insulation materials and particular constructions which minimize direct paths for thermal conduction, by thermally separating one face of the frame from the other. Diagram shows a typical example.

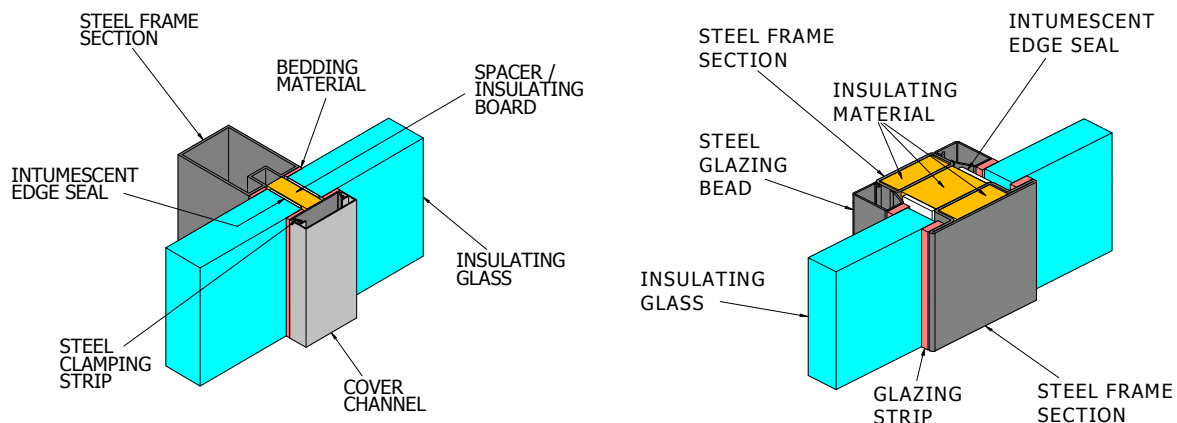

Diagram 9 – Examples of Steel Framing systems for Integrity and Insulation

Never:

- Use any systems other than those that are designed specifically for fire-resistance and have the necessary, and relevant, evidence of performance
- Make any changes to the system as supplied
- Use insulation glazing in integrity only framed systems for insulation performance
- Use modified toughened soda-lime fire-resistant glass types in insulation rated metal framing systems

Section 6

Metal Systems for Screens and Doors

Pressure glazed systems

Edge pressure can be applied to the glass by the tightening of screws or bolts onto steel plates, around the perimeter of the glass. Pressure glazed framing can increase the length of time that certain integrity-only glass types are retained within the frame during a fire. It is only of benefit for fire-resistance periods of 60 minutes and longer.

In general there are two types:

- Lipped channel glazing, in which pressure generating intumescent strips are fitted between faces of the glass and the inside of the special glazing channel
- Mechanical retention, the simplest pressure glazing system, which requires the use of back-to-back steel angles with pressure plates holding the glass edge in position during the latter stages of the fire

It is important with the mechanical retention design that the pressure is applied equally around the perimeter of the glass to avoid uneven loading of the glass.

Pressure glazing can have a detrimental effect on the fire performance of modified toughened soda-lime silicate fire-resisting glass, because of the critical need to avoid undue edge stresses (e.g. due to restrained expansion). Uneven pressure points can therefore exacerbate this situation.

Note:

- The use of angles or back-to-back angles to form a glazing rebate, does not automatically imply that the system is pressure glazed
- Existing systems cannot normally be readily modified to be pressure glazed because the alterations have to be precise in respect of both materials and design
- When re-glazing a pressure glazed system the design and installation details must be exactly as given in the original test or assessment (which applies to the specific glass, glass size, glass thickness, glazing seal, bead details and fixings).

The fire-resistance of a mechanical pressure glazed system is dependent on the application of a designated pressure. It is therefore essential that the designated specification pressure be applied during the re-glazing. Failure to comply can cause the system to fail prematurely.

Pressure glazing systems

The glazing pressure is specific to the individual glass products being used and manufacturer's stipulated guidelines must always be followed for the framing system being considered

Section 6

Metal Systems for Screens and Doors

Glazing seals for metal framed systems

A range of different materials may be used according to the specific glazing system. The most common type of glazing seal used in steel frames is ceramic fibre tape.

Always use the approved seal material as specified for each particular glazed system, and never make substitutions of materials, unless approved by a competent authority and endorsed by the supplier of the glazed system.

Frames for external applications (drained and ventilated systems)

When using fire-resistant glazed systems in external applications the framing system must follow the normal requirements of external systems to allow any moisture that enters the frame to escape (known as “drained and ventilated” systems). This is normal practice for external glazing. Laminated EI fire-resistant glass is particularly susceptible to the effects of moisture ingress and must be suitably protected.

Curtain walling systems

The specimen of the system when fire tested in a fire test furnace must include all the system elements to verify its fire-resistance performance.

On installation, there is the potential for a gap to exist between the approved façade construction and the adjacent floor slab. Adequate fire stopping must be used to fill this gap to prevent the movement of fire, flames and smoke between floors. The supplier of the curtain wall must provide this level of detail.

Factors to consider are:

- Connections to the supporting structure and their adequacy in fire conditions
- Exposure of the curtain wall element to fire exposure either from below or above
- The linear gap between the curtain wall and any of the surrounding or supporting structure
- Any cavities that may be provided for within the curtain wall design
- The provision of appropriately fire rated spandrels between the glazed sections

Table 7—System and Trade names of fire-resistant metal screens and doors

System Name or Trade name	Fire Resistance Integrity/Insulation	Additional Comments	Manufacturer
Clear Run	EI30	Glazed Screens	C3S Securiglass
	EI60		

Section 7

Frameless (butt-jointed) Systems

Section Contents:

- Types of systems
- Perimeter framing
- Available systems

Types of systems

Frameless, or butt-jointed, fire-resistant glazed systems are also available to complement similar designs in non-fire rated applications. There are integrity-only systems (using Thermally Toughened Borosilicate Glass) and insulation with integrity systems (using multi-layer intumescent glass). Examples are shown in Figure 10 & 11.

In such systems, the mullions separating and retaining the glass panes are replaced by an intumescent compound that remains in position in the event of fire to prevent the passage of flames and gases to the non-fire side. A horizontal support framework retains the glass in position at the head and sill.

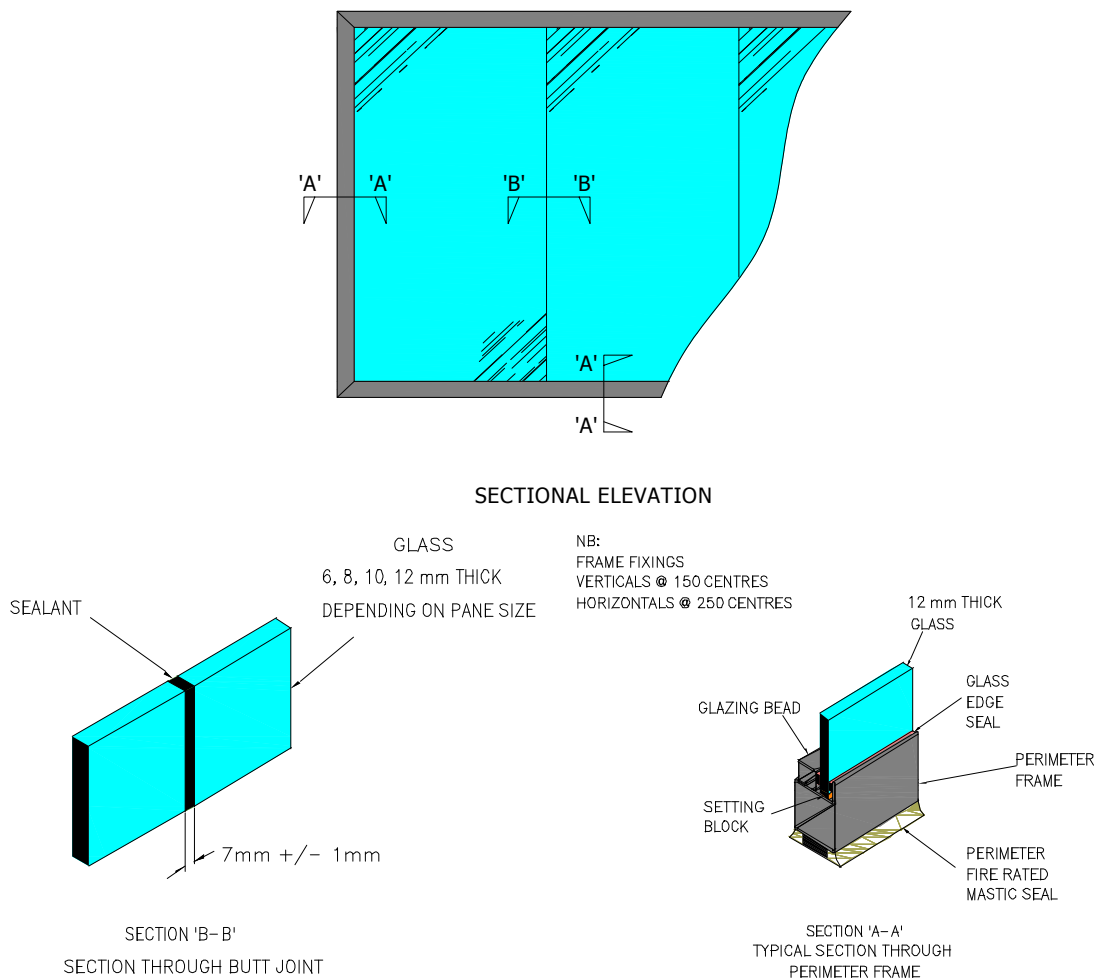

Diagram 10 – Example of 30 minute integrity only fire-resistant butt-joint system

Section 7

Frameless (butt-jointed) Systems

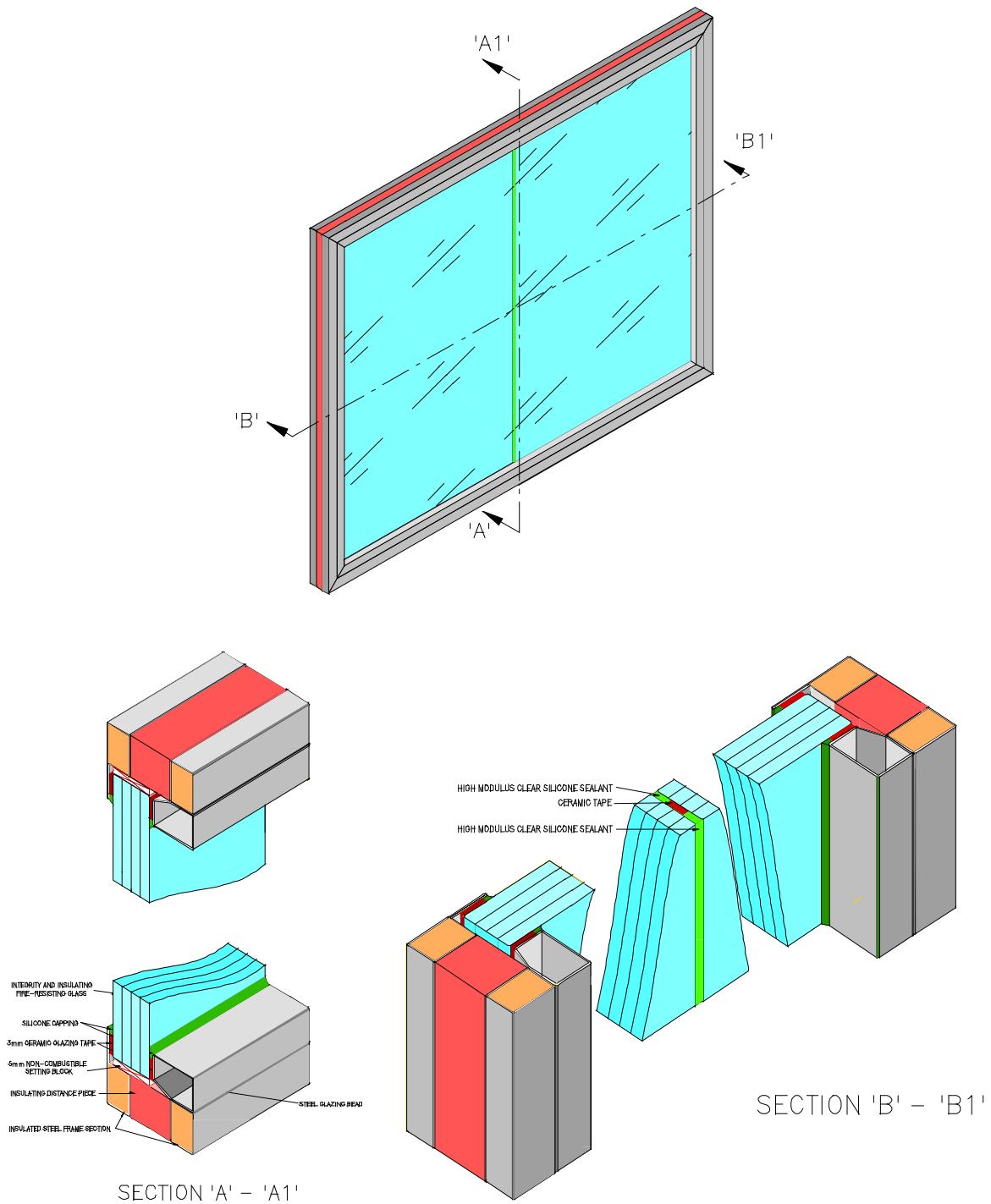

Diagram 11 – Example of integrity and insulation fire-resistant butt-joint system

Section 7

Frameless (butt-jointed) Systems

Perimeter Framing

The perimeter framing is a purpose-made construction that is specific to each manufacturer and is typically steel or timber. Other materials have been tested and can be used to suit individual design solutions.

For integrity rating an approved E integrity framing system can be used and for integrity and insulation systems will be constructed using approved EI framework, both types should be designed for the appropriate fire rating, i.e. 30, 60, 120

The minimal framing of butt-jointed systems means that the surrounding structure must be substantial enough to support the weight of the glass and the forces that the system may be subjected to. The surrounding structure must also be of equal or greater fire-resistance than the glass. In addition, because the glazed area normally consists of large panes, visual quality and lack of optical distortion are also important.

Butt joints between adjacent panes of glass are usually vertical but may be horizontal. In both cases test evidence or assessment must be available to support the design.

Available systems

Systems are also available using minimal width profiles, which are essentially decorative, covering the vertical joints. In some alternative designs, the joining reinforces the joint in the event of fire and ensures that the two glass panels are held in position to prevent the passage of fire and flame.

Note:

- **Specialist frameless systems have been tested from 30 minute integrity (E30) up to 120 minutes integrity and insulation (EI120)**
- **There must be no interchange of components between different systems otherwise the fire-resistance performance of the screen will be compromised, unless approved by the system designers/ test house**
- **When installing insulation butt jointed systems, all joints must be fully sealed at the time of installation. Insulation glass must not be**

Table 8 - System and Trade names of fire-resistant frameless screens and doors

System Name or Trade name	Fire Resistance Integrity/Insulation	Additional Comments	Manufacturer
Pyrovista	EI30 EI60	Timber framed butt-jointed system	Mann McGowan
Pyrobel Vision Line	EI30	Timber framed butt-jointed system	AGC
	EI60		
	EI30	Steel framed butt-jointed system	

Section 8

Fire-Resistant Glass Floors

Section Contents:

- Essential requirements
- Fire performance requirements and testing
- In service functional requirements
- Additional functional properties
- Systems
- Connections and gasket
- Installation

Essential requirements

Flooring is a load-bearing element and will often form an essential part of the escape, fire separation and compartmentation fire safety strategy of a building. It is unusual for glass to be used in structural loading applications but there are now some special fire-resistant glass load-bearing floor constructions available (based on properly tested systems) that allow the designer full scope in the use of glass throughout a building to maximise the benefits of natural lighting, as well as opportunity to create eye catching internal visual effects.

Where load-bearing glass floors are concerned, however, fitness for intended purpose is critical. It is implicit that the structure should be stable under fire exposure and that the heat transmitted through the structure should be at a minimal level, both to retain structural stability and to create tolerable conditions for those who may have to travel along the floor with fire underneath.

It is essential that a fire-resistant floor construction should maintain its structural stability and load-bearing capability throughout any potential fire because of the fundamental consequences for the rest of the building. In particular, as recommended by Approved Document B Vol 2 (section 8.20) every compartment floor should form a complete barrier to fire between the compartments they separate.

Fire performance requirements and testing

The performance requirements recommended by AD B are given in Table A1 of Appendix A in the document. The most common requirement is for 60 minutes load-bearing, integrity and insulation, i.e. 60/60 (with higher required classification times in some circumstances, especially for buildings higher than 18m). There are also some limited applications for 30 minutes classification times (load-bearing, integrity and insulation), i.e. 30/30, mainly in residential buildings no higher than 5m.

Where floors are concerned, it is especially important to note the following from Approved Document B Vol 2 Appendix A:

“Where one element of structure supports or carries or gives stability to another, the fire resistance of the supporting element should be no less than the minimum period of fire resistance for the other element (whether that other element is load-bearing or not)”.

The applicable fire test standard is BS EN 1365-2, Fire resistance tests for load-bearing elements. Floors and Roofs

A Certificate of Conformity must be raised by the certificated installer company for

Section 8

Fire-Resistant Glass Floors

each installation and this documentation should be retained with the building documentation and passed on with the building when ownership changes.

BS EN 1365-2 requires that the test specimen be subjected to appropriate loads in accordance with general provisions given by BS EN 1363-1:1999, Fire resistance tests - General Requirements. The tested system should be fully representative of the proposed floor structure; and the magnitude and distribution of the load shall be such that the maximum moments and shear forces produced in the test specimen are representative of, or higher than, those expected in service. The applicable furnace time/temperature relationship is as detailed in BS EN 1363-1.

It is important to note that the floor construction should accordingly have applicable fire test evidence under full loading conditions throughout the length of tested fire exposure. This evidence should be provided via an approved test report. The determination of the load should be clearly indicated in the test report, as required by BS EN 1365, and the sponsor of the test shall provide the justification for the test load selection, including any calculation if the test load is based on material properties.

The deflection of the system is measured before the test and throughout to reflect changes in its mechanical stability as the test progresses. BS EN 1365-2 requires that the system be tested with a combination of the concentrated and uniform loads applied simultaneously for the duration of the test.

The selected test load (both uniformly distributed and concentrated loads) should be appropriate to the type of activity and occupancy of the application. Guidance should be taken from BS EN 1991-1-1 Eurocode 1. Actions on structures.

For example:

Categories of loaded areas	q_k Uniform load (kN/m ²)	Q_k Local load (kN)
Category A - Domestic		
- Floors	1.5 to <u>2.0</u>	<u>2.0</u> to 3.0
- Stairs	<u>2.0</u> to 4.0	<u>2.0</u> to 4.0
- Balconies	<u>2.5</u> to 4.0	<u>2.0</u> to 3.0
Category B - Offices	2.0 to <u>3.0</u>	1.5 to <u>4.5</u>
Category C - Commercial		
- C1	2.0 to <u>3.0</u>	3.0 to <u>4.0</u>
- C2	3.0 to <u>4.0</u>	2.5 to 7.0 (<u>4.0</u>)
- C3	3.0 to <u>5.0</u>	<u>4.0</u> to 7.0
- C4	4.5 to <u>5.0</u>	3.5 to <u>7.0</u>
- C5	<u>5.0</u> to 7.5	3.5 to <u>4.5</u>
Category D - Shopping areas		
- D1	<u>4.0</u> to 5.0	3.5 to 7.0 (<u>4.0</u>)
- D2	4.0 to <u>5.0</u>	3.5 to <u>7.0</u>

Extract from BS EN 1991-1-1:2002 - Eurocode 1. Actions on structures. General actions. Densities, self-weight, imposed loads for buildings

Ranges of values—recommended values are underlined

Section 8

Fire-Resistant Glass Floors

A load-bearing fire-resistant glass floor may be fully supported along all edges or partially supported on at least 2 edges depending on the application and associated specification. In this case the critical dimension for load calculation shall be considered as the shortest span. Therefore if the span increases the loads that may be applied will reduce, or an alternative specification for the loaded panel should be considered.

Above all, it is important that the service application of the floor is at, or within, the limits of the tested load, as specified in the test report.

In service functional requirements

A tested fire-resistant glass floor system combines different glass layers and suitable framing. As the system heats up, the characteristics of the framing and glass may well change, therefore potentially affecting the ability of the structure to withstand applied loads. This consideration is crucial in a design evaluation of fitness for use in case of fire. The fire-resistant floor system should therefore demonstrate that it can:

- Withstand the concentrated and uniform loads detailed in BS EN 1991-1-1 for the application
- Withstand those loads for the duration of the fire test without failure or significant distortion, as detailed in the applicable test standards
- Resist significant increases in temperature on to the loaded surface
- Prevent significant heat transfer within the body of the structure itself that would disrupt the essential bonded stability of the structure

Systems may utilise toughened glass or laminated glass in the upper load-bearing panel, with a lower panel of rated fire-resistant glazing which may require insulation performance (i.e. EI) fire-resistant glass to provide the lowest risk of heat transfer into the structure, thereby limiting the potential risk of heat exposure of sensitive lamination layers within the structure. This lower panel may be bonded by lamination to the loaded panel or separated by an air gap. If toughened glass is used in the load-bearing part of the structure then recommended best practice is that each toughened glass layer is duplicated by a second adjacent toughened glass layer to ensure sufficient security in the event of failure of one of the toughened glass layers.

It is important that separate consideration be given in design both to connections of the floor structure to the surrounding structure and to the consequential movements that may be transferred. The floor specification may also need to comply with the general requirements for overhead glazing.

Additional functional considerations

Other key properties need to be considered because of the application. This in particular includes slip resistance, the required level of privacy, pattern or obscuration and the acoustic performance of the floor. The floor specification should also comply with the practice for overhead glazing of minimising the risk of falling glass during normal use (i.e. preferably no exposed toughened glass in the underside layer).

Where slip resistance is concerned the particular guidance should be obtained from the client to ensure compliance with any health and safety risk assessment that may have been carried out for the application. Note should

Section 8

Fire-Resistant Glass Floors

also be taken of recommendations in Approved Document B that floorings on escape routes should be chosen to minimise their slipperiness when wet.

The acoustic attenuation performance of the floor may need to be particularly considered to minimise migration of internal noise through the structure between adjacent spaces. Guidance is provided by Approved Document E (Resistance to the passage of sound) to minimise disruption from background noise levels for internal living spaces. A target is given by the AD of at least 45dB for the measured standard differential acoustic factor $\{DnT,w\}$ between two adjacent enclosed spaces. Given that the glazed floor element will be part of a surrounding structure that will in total influence the sound levels, the recommended rule of thumb for the glazed floor element is a determined R_w acoustic factor in the region of 48dB. In all cases, the acoustic performance of the whole structure should be evaluated by an acoustics expert because of the influence of frequency and flanking factors.

Systems

Any system considered must have an applicable test report showing test evidence appropriate to the proposed application. Relevant standards include BS EN1365-2, BS EN 1363-1, BS EN 12150 (toughened glass), BS EN 1279, BS EN 12543 1-6 and BS EN 14449 (level 1 attestation) since the glass structure normally includes laminated layers. It is recommended that the floor system should be based on CE marked glass with an appropriate certificate of attestation, in accordance with the relevant essential requirements of the Construction Products Directive, in view of the high performance requirement of the application regarding load-bearing capability under fire conditions.

The framing should be manufactured strictly to the submitted test design with adequate fire protection.

Connections and Gaskets

When designing the connection detail the stability of the surrounding system should be confirmed by the client's engineer. The specific connection may be adjusted subject to specific project conditions and fixing regimes must be detailed on the construction drawings submitted for approval.

Gaskets and seals used shall be as per the submitted test design. Fire resistant materials should be provided by an approved manufacturer with relevant test evidence.

Key specification check list

- Required fire –resistance classification
- Fire-resistance of elements supported by the floor
- The loads to be applied to the system
- The required level of slip resistance
- Acoustic performance and specification (see section)
- Internal or external application (U-value if applicable)
- Level of privacy and obscuration required
- Fire-resistance of surrounding elements
- Weights of installed floor elements for installation handling assessments
- Conformity to CDM requirements for installation and replacement

Section 8

Fire-Resistant Glass Floors

External load-bearing fire-resistant floors

It may be necessary to install fire-resistant glass floor externally, if this is required it is necessary to also consider the thermal insulation requirements of the Building Regulations. Approved Documents L contain methods of achieving these requirements with calculation methods based on the U-value of the glass.

Specifications, supported by calculations, will be required to demonstrate compliance with the Building Regulations.

Consideration should also be given to UV stability when exposed to sunlight.

Installation

Installation must be carried out by the manufacturer's trained staff or licenced operators to the manufacturer's specification.

Documents relating to the construction, its specification and attested fire performance should be handed over on completion, in accordance with the requirements of Approved Document B and the Regulatory Reform (Fire Safety) Order (or equivalent in Scotland and N. Ireland).

Key knowledge check list

- Requirements to BS EN 1365 –2
- Requirements to BS EN 12543-1 to BS EN 12543-6
- Requirements to BS EN 14449
- Requirements to BS 1991-1-1
- Requirements to BS EN 1279 for IGU units
- Slip resistance compliance reference client's health and safety risk assessment

Section 9 - Refurbishment and Replacement of Fire-Resistant Glazing

Section Contents:

- Refurbishment of fire-resistant glazed door and screen
- Replacement glazing in doors, frames or screens manufactured from materials other than timber or steel
- Marking of fire-resistant glass
- Supporting construction
- Maintenance and aftercare
- Fire stopping
- Storage and transport of fire-resistant glass
- Records and documentation
- Replacement glazing in frames manufactured from materials other than timber or steel

Best Practice Rule No. 12

Any components within a fire-resistant glazed system must be replaced with the same material on a like-for-like basis to avoid compromising the specified fire performance.

Refurbishment of fire-resistant glazed doors and screens

Recommended best practice

Any refurbishment involving replacement of components must be carried out exactly according to the original specification of the fire-resistant system as installed, providing that the fire risk has not changed. This must be confirmed by the Responsible Person for the building.

The original documentation provided on installation must be consulted and components must be replaced with the original material as specified.

If individual components cannot be replaced with the same components then the complete glazed system must be replaced with an equivalent system.

Note:

If the fire risk has changed then a complete new fire-resistant glazed system may have to be installed to meet the latest requirements. In this case, the installer must confirm the requirements for fire safety in the building concerned with the Responsible Person, as defined under applicable legislation. The installer must also provide the appropriate test evidence of performance to suit the proposed application.

It should be recognised that it may not be possible to follow the recommended best practice, for a number of valid reasons, such as:

- The required specification may not be available, or may be unclear
- Some of the components may no longer be available
- Marking on the glass may be absent or unreadable
- In some buildings, such as historical heritage buildings, current practice

Section 9 - Refurbishment and Replacement of Fire-Resistant Glazing

and regulation governing fire safety is likely to be different from any that which might have applied when the building was constructed

Under these constraints, a practical approach has to be taken and the general guidance given below may help. But this advice should not be regarded as a substitute for first hand guidance on site from a specialist in fire-resistant glazing systems. For this guidance, please contact the appropriate member of the Fire Resistant Glazing Group (see Appendix A).

This route should only be taken when there is no alternative and when the best practice recommendation given above cannot be followed.

Glass

It is very difficult to differentiate between different types of fire-resistant glass when they are glazed. One way is to examine the product stamp which should always be present and visible.

If however, the glass is broken then the stamp will not be readable for modified toughened or toughened borosilicate glass, so it will be impossible to identify the manufacturer either from the stamp or from the fracture pattern. It may be possible to indicate whether a modified toughened soda lime silicate glass has been used from the height of the bead edge cover as it should be no more than 10mm. For borosilicate this edge cover height may be up to 25mm so if the glass is clear and the edge cover is more than 10mm borosilicate should be used as a replacement.

For wired glass, as the glass does not break into many small pieces like toughened glass, it may still be possible to identify the manufacturer if the glass is stamped. The specific source of wired glass is important, as fire test approvals are specific to the particular glazed system and the particular glass, not the generic glass type.

For fire-resistant laminated glass it can be possible to identify the glass type after the breakage from the stamp or, if not, by examination of the interlayer but this requires specialist advice from the glass manufacturer.

Special care should be taken to ensure that standard laminated glass for impact safety purposes (pvb laminate), which does not have any significant resistance against fire, is not confused with fire-resistant laminates based on special intumescent or other fire retardant inter-layers.

Timber doors

It might be possible to identify the fire-resistance period of the door if it carries markings originating from one of the available certification schemes, e.g. CERTIFIRE, BWF CERTIFIRE or the BM TRADA Q Mark.

Contact the responsible certification authority for confirmation, as appropriate.

If this is not possible then the door thickness could be taken as a guide. A 43-46mm thick door is normally rated for 30 minutes, but if the thickness is over 50mm

Best Practice Rule No. 13

Any components within a fire-resistant glazed system must be replaced with the same material on a like-for-like basis to avoid compromising the specified fire performance.

Section 9 - Refurbishment and Replacement of Fire-Resistant Glazing

then it is possible that the door is rated for 60 minutes.

Examination of the glazing beads can reinforce this conclusion. For 30 minute applications the bead size is typically in the range 12 to 18mm deep whereas beads used to achieve 60 minute beads are typically 25 to 35mm deep. Systems for 60 minute should also have a lining strip between the bead and the glazing aperture in the door.

Identification must not be based on just one factor in isolation.

Glazing seals

Seals are typically placed between the glass and the bead face on glazing, but some manufacturers use a seal applied around the periphery of the glass. This must not be confused with a lining strip which is laid underneath the beads across the full width of the door. In some special applications with elastomeric channels, a lining strip is used even on 30 minute applications but the bead depth can then serve as an alternative indication of fire performance.

Damaged beads must be replaced with the same timber as used originally, and the section must be the same.

Bead fixings are important and the type and length used originally must be replicated. The manner of fixing (e.g. screws or pins, types and gauge, angle of fixing and fixing centres) must also be replicated as originally designed. For 60 minute applications the screws or pins must be long enough to reach timber on the other side of the glass from which they are applied (normally 70mm).

Seals are often untraceable. Where there is no indication of the manufacturer of the product, advice should be sought from glass/glazed system or seal manufacturers on a suitable replacement product compatible with the fire-resistant glass. Intumescent seals may be marked with the seal manufacturer's name but this not always the case.

Timber Screens

An examination of bead depth may indicate the fire-resistance rating of the screen. Confirmation can include the presence of a lining strip which is unusual in 30 minute screens or doors but is typical for 60 minute screens and doors.

Replacement of the beads and fixings must follow the guidance given for timber doors (i.e. substitute on a "like for like" basis) but fixings for 60 minute applications must be long enough to reach timber on the other side of the glass from which they are applied (normally 70mm).

Steel doors and screens

The ceramic fibre seal must be replaced when replacing the glass, to avoid any sharp debris that could cause the glass to crack when the beads are refitted. The same material must be used as originally specified and this must be established by contacting either the glass manufacturer or the supplier of the system.

Upgrading of timber doors and screens

The upgrading of existing installations must only be considered in abnormal situations where there is absolutely no alternative. It is preferable to replace with an assembly that meets the latest requirements outlined in regulatory guidance.

Section 9 - Refurbishment and Replacement of Fire-Resistant Glazing

Protected buildings and historical context

The modification of existing historical glazed situations to bring them up to modern fire standards is a specialist area requiring input from a specialist in fire-resistant glazed systems. This can be especially difficult in protected buildings where it is important to preserve the historical style and context of the structure. However, it will generally be possible to make improvements, subject to obtaining this specialist site specific advice.

It is highly unlikely that the upgrading of an existing door or screen in this context can achieve a fire performance comparable with modern practice.

It may be possible to develop a specific tailor-made solution for the particular situation under consideration.

One approach, for example, is to install a complete glazed system - glass, bead, fixings, and seal - as a new unit in front of the existing glazed section. In this case, it is normal to identify the side of greatest fire risk and apply the secondary glazed system on that side. All improvements must be made together with the Responsible Person for the building itself.

Best Practice Rule No. 14

The glazing system must be installed in a supporting structure which has a fire rating at least equal to that of the glazing system being installed.

Replacement glazing in doors, frames or screens manufactured from materials other than timber or steel

It may be necessary to replace glazing in a fire-resistant building element (door, window, screen etc.) where the framing is manufactured from a material other than timber or steel, such as PVC-u or modern composite materials (GRP/ Thermoplastic/ Foams/Timber/Engineered timber). These elements are usually supplied to site glazed and should they require re-glazing on site due to damage or breakage, the original manufacturer must be identified and contacted to confirm the exact glazing specification. Re-glazing of the element must be carried to this exact specification to ensure performance in accordance with the original test evidence or assessment.

It is very unlikely that the fire resistance of an existing element can be improved without replacing the element with one designed and tested or assessed to the new required specification. Should an upgraded element be fitted, the supporting structure must be checked to confirm it will also perform to the new requirement.

Marking of fire-resistant glass

Fire-resistant glass should carry a permanent mark (for example, of the type normally applied for impact safety). This mark must show as a minimum the glass product name, supplier and safety impact rating if required. In some cases, additional information such as the fire performance classification for the glass may also be given.

Section 9 - Refurbishment and Replacement of Fire-Resistant Glazing

Any identifying marks on the glass must be visible and legible after glazing.

The important reasons for marking the glass in this way are as follows:

- Confirmation and ready crosschecking against building specification that the specified glass has been installed
- Information for those carrying out fire risk assessments
- Notification of the glass type and manufacturer in case replacement is necessary.

Marking with the name of the particular glass product that has been installed is particularly important for non reinforced fire-resistant glass types since they cannot be individually identified when glazed without such a mark (for example modified toughened soda lime glass or borosilicate).

Such an identifying mark on the glass must not be taken as applying to the whole of the glazed system. There must be appropriate evidence of performance for the system as a whole, and the fire-resistant glass must be approved as an integral part of that system. Reference to this evidence must be given in the documentation provided on installation.

The mark on the glass should therefore be taken as only an indicator for the system as a whole. Confirmation that a suitable system has been installed, and the rating of that system, must be available in accompanying documentation.

Supporting construction

The supporting construction into which the framed assembly is to be fitted must be checked to make sure that it is satisfactory to take the fire-resistant glazed element.

Important checks are that:

- The opening is correctly sized and prepared so that the frame fits within defined tolerances
- The correct expansion allowance is provided
- The supporting structure is strong enough to withstand any forces generated by the glazed element in a fire
- The types of fixings are suitable for the supporting substrate, and sufficiently fire-resistant
- The fixings are capable of supporting the weight of the fire-resistant glazed assembly
- The supporting structure is sound and robust
- Any shims used to position the framed assembly in the supporting construction do not interfere with the required expansion of the assembly

Best Practice Rule No. 15

It is always important to seal the gap between the frames and supporting structure without compromising any expansion for the assembly as a whole.

Section 9 - Refurbishment and Replacement of Fire-Resistant Glazing

in a fire situation

Supplier's installation instructions must be followed at all times.

The type of supporting structure must be the same as that tested, or assessed. For example, a test in a rigid supporting structure does not necessarily and automatically cover fixing to a flexible supporting structure, and vice versa.

Maintenance and aftercare

Special maintenance procedures are not required.

However, regular visual inspection of fire-resistant glazing should be carried out as part of the fire safety risk assessment routine for the building, to ensure that the original fire-resistant glazed installations have not been damaged, either maliciously or during normal building use.

This inspection as a minimum should examine:

- The presence of any significant cracks, scratches or surface damage on the glass (which is particularly important for modified soda-lime silicate toughened glass and borosilicates since surface damage can dramatically affect fire and impact performance of this type of fire-resistant glazing)
- The gaskets, glazing strips, mastics, or seals around the glass for signs of significant deterioration, damage or missing sections (including any hot or cold smoke seals)
- The intumescent seals fitted to the top and sides of fire doors to ensure that they are in the correct position, not significantly damaged or have missing sections
- The beads and bead fixings, to ensure that the bead is securely held in place
- The frame sections to ensure that they are fixed securely and not working loose
- Door hinges, mechanical closers, handles, locks and other parts of door hardware to ensure that they are functioning as intended

Should the inspection raise any major concerns about the condition of the fire doors or screens which could impair fire performance then a full overhaul should be instigated as soon as practical. This may require either repair or replacement.

Fire stopping

Where the gaps are to allow for expansion they must be sealed as directed, but care must be taken to ensure that a flexible and non-combustible backing material is used rather than a rigid one.

If no expansion allowance is specified then fire stopping may be carried out using non-combustible and temperature-resistant materials such as board, medium density mineral fibre, intumescent or non-intumescent seals, subject to installation instructions.

Section 9 - Refurbishment and Replacement of Fire-Resistant Glazing

Storage and transport of fire-resistant glass

All reputable manufacturers will supply guidance on handling, storage and transport for their proprietary fire-resistant glass products. These recommendations must always be followed.

In all cases, the necessary glass handling or lifting equipment must be used.

The standard practice for storing glass must be followed: it must be kept dry and protected against the weather, and properly stacked on suitable stillages to avoid edge damage and breakage. The stillages should also be stored for easy access and handling.

Records and documentation

It is the contractor's responsibility to ensure that adequate documentation and confirmation of the installed fire-resistant system are provided.

This documentation normally includes the following at different stages:

- On submitting a tender, full specification and description of the system that would be provided
- On confirming an order, a method statement and risk assessment
- After installation, an operation and maintenance manual which confirms the work completed.

A suitable operation and maintenance manual normally provides the following, as a minimum:

- A drawing of the system as installed together with a description of main features and dimensions
- Test and commissioning certificates which include evidence of fire performance clearly referenced to relevant test evidence
- Confirmation of suppliers and a listing of main components by name
- Advice on maintenance requirements and actions for damage repair

Certification from third party schemes, or manufacturer's information on applicable CE Marking, may also be provided, if available.

Reports of post-installation inspections must also be noted, as appropriate, and a record kept of any replacements, lodged with the appropriate Responsible Person (under appropriate legislation).

Section 10

Frequently Asked Questions

Q1 Where must fire-resistant glass be used?

A1 Fire-resistant glass is normally used to prevent fire spread and to provide a safe escape route and safe access for firefighters. The national documents providing guidance on how to meet Building Regulations (e.g. Approved Document B for England and Wales) show where fire-resistant barriers are required. If an alternative approach has been taken to demonstrate compliance with Building Regulations, such as a fire safety engineering design study, then the applications for fire-resistant glass must be specified in the appropriate design report.

[Section 1](#)

Q2 When must the glass be integrity-only and when must it have insulation performance?

A2 The areas of application for integrity-only or integrity and insulation performance are given in the appropriate guidance to the Regulations, or in the appropriate design report if the building is subject to a fire safety engineering study.

[Section 1](#)

Q3 How can it be ensured that the specified system is appropriate for the application?

A3 The specified glazed system must have appropriate evidence of performance based on appropriate test information. This evidence may be provided either in a test report, or in an assessment report or by third party certification. The test evidence that is provided must be appropriate to both the application and the specific glazed system that is to be installed.

[Section 2](#)

Q4 Is it possible to obtain a fire certificate for installed fire-resistant glass products?

A4 Fire certificates are provided by the Fire Service to approve certain premises and are not applicable to individual products, systems, assemblies or installations. Under new Regulations, fire certificates are to be phased out during 2006 and replaced by making the Responsible Person, i.e. the building or business owner, responsible for ensuring that appropriate fire precautions and safety measures are in place. Product certificates may be referred to in the context of third-party certification schemes, but these are voluntary and not obligatory. The appropriate evidence of performance for a fire-resistant glazed system is normally a test or an assessment report, which must be provided by the supplier on request.

[Section 2](#)

Q5 Why can't toughened glass be used for fire-resistant applications?

A5 Standard toughened glass is not able to withstand the thermal shock generated during a fire and it must not be used where fire-resistant barriers are required. There are a number of specially modified toughened soda-lime glass types available for fire-resistant applications in very specific framing systems, or special glass compositions such as toughened borosilicates that can be used, but

Section 10

Frequently Asked Questions

both types are strictly subject to manufacturers' specific guidance on their use.

[Section 3](#)

Q6 Can it be assumed that a fire-resistant glass successfully tested in single glazing will give the same performance in an IGU?

A6 Never make assumptions. In all cases appropriate proof of performance must be available related to appropriate test evidence.

[Section 3](#)

Q7 What is the biggest pane size that can be used?

A7 The pane size will vary according to the glass and framing system, always subject to the availability of appropriate test evidence. In every case, contact the glass manufacturer or supplier for the maximum glass sizes tested and the associated framing system details.

[Section 3 and Appendix A for a listing of glass manufacturers & suppliers.](#)

Q8 What edge cover should I use when glazing fire-resistant glass?

A8 Different glass types will require different amounts of edge cover according to their individual requirements. Manufacturers/suppliers will provide appropriate guidance, which must be followed. Modified toughened soda-lime glasses are particularly sensitive to edge cover which is generally a maximum of 10mm cover. If the edge cover is too great for this type of glass then premature failure is far more likely.

[Section 3 and Appendix A for a list of glass manufacturers and suppliers.](#)

Q9 When glazing, must I allow for expansion of the fire-resistant glass?

A9 Normal glazing codes of practice must be followed. Glass in any application must never be glazed tightly. Expansion allowances can be especially critical for modified toughened soda-lime glass types. The glass manufacturer/supplier will define expansion allowance required.

[Section 3](#)

Q10 Can PVB laminated glass be used for fire-resistant applications, as it is a safety glass?

A10 PVB laminated safety glass does not have any fire-resistant properties and it must not be used in fire-resistant applications. Safety glass types with fire-resistant properties are available, based upon special interlayers.

[Section 3](#)

Q11 Can the maximum pane size be increased beyond what was tested?

A11 Only limited increases in tested pane sizes are allowed, according to assessment. The evidence provided by the glass manufacturer/supplier will provide the maximum pane size for each particular system.

[Section 2](#)

Q12 Can the pane height be increased while reducing the width, keeping the same area?

A12 This is only possible if there is test evidence that the modified dimension

Section 10

Frequently Asked Questions

meets the fire-resistance performance. Details will be made available by the glass manufacturer/supplier.

[Section 2](#)

Q13 What size and shape of glazing bead can be used?

A13 This information can only be identified by reference to the approved glazing systems, and the size of bead will vary according to the glass and system chosen.

[Section 5 and Appendix A.](#)

Q14 Can the tested gasket or seal be exchanged for an alternative?

A14 This may be possible but only if the alternative has documented evidence showing that it can be used with the glass and framing system. If this evidence is not available, contact the gasket or seal supplier for confirmation of acceptability.

[Section 4](#)

Q15 What glazing seals must be used?

A15 The glazing seal has to be appropriate for the chosen system based on test evidence. Standard glazing seals must not be used for fire-resistant glazing.

[Section 4](#)

Q16 How big a piece of glass can be installed into a timber fire door leaf?

A16 This depends on the door leaf being used, as each door manufacturer will have tested different sizes of glass with their door leaf types. Maximum glass size can also depend on the glazing system being used in the door. The test or assessment information for the specific door leaf and glazed system will dictate the allowable maximum glass size and glass aspect ratio. It should be noted, that great care needs to be taken when cutting apertures into door leaves because this can adversely affect the fire-resistance performance of the door and this must only be done according to the door manufacturer's guidance and instruction. Impact safety may also limit maximum glass size: if the glass has a class C impact safety rating then glazed door panels are limited to a maximum of 900mm.

[Section 2 and Appendix B](#)

Q17 What shapes of vision panel can be used in a timber door leaf?

A17 Various shapes are possible but the types and sizes will depend upon the evidence available for the door leaf and the glazing system. If the evidence is unavailable for the required shape, then the shape must not be used. It should be noted that great care needs to be taken when cutting apertures into door leaves because this can adversely affect the fire-resistance performance of the door.

[Section 2](#)

Q18 What happens if a different species of timber is used?

A18 Different timbers have different burning characteristics and can influence the performance of the door or framing system. An alternative timber should not be used unless there is appropriate fire test evidence.

[Section 5](#)

Section 10

Frequently Asked Questions

Q19 What is the minimum frame section that may be used in a timber glazed system?

A19 The minimum section will be the size that can be demonstrated to work with the chosen fire-resistant glass. This can be identified by reference to fire test report. Contact the glass manufacturer/supplier for the appropriate information.

Section 5 and Appendix A

Q20 Can square timber beads be used for fire-resistant glazing?

A20 Yes, in certain cases. For insulation glass types, in particular, square beads present few problems but integrity-only glass types require more detailed consideration as transferred heat can lead to bead ignition on the protected face. Partial insulation glass types may also allow the use of square beads, subject to appropriate evidence of performance based on tests.

Section 5

Q21 Can fire-resistant glass be installed into metal frames?

A21 Steel and aluminium framing systems may be used but only if the frame is specifically designed as part of an approved fire-resistant glazed system. Standard steel or aluminium framing systems are not suitable for fire-resistant applications.

Section 6

Q22 Can fire-resistant glass be installed into frameless systems?

A22 Yes, by using specialist glass and glazing systems that have the appropriate fire test evidence. Contact the glass manufacturer/supplier for the appropriate information.

Section 7

Q23 Is it possible to have glass supplied for installers to fit within their own frames?

A23 All glass types are available on a supply-only basis but it must always be fitted into a frame that has the appropriate test evidence, using the glazing seals and bead types that are approved for that particular glazed system. Competent persons who have the relevant specialist knowledge must always carry out the installation of the glazed system, according to the construction and components given in the accompanying evidence of performance. Fire-resistant glass must only be used as part of an appropriately approved glazed system.

Section 9

Q24 The glass in an existing aperture must be replaced, can a suitable glass be supplied?

A24 All fire-resistant glass types may be used in refurbishment glazing but the glass and seals must be replaced on a like-for-like basis in the existing frame according to the original evidence of performance provided for the particular glazed system as installed. When carrying out any replacement glazing, the frame must be checked to ensure that it is in a suitable condition for re-glazing to be carried out. In all cases, the replacement must be an approved fire-resistant

Section 10

Frequently Asked Questions

glazed system with appropriate evidence of performance, and the performance rating of that system must be appropriate to the latest guidelines, for example as given in the latest version of Approved Document B (England and Wales). If there is any uncertainty about any of the components that have to be replaced, or uncertainty about the performance rating that is required, then expert guidance must be sought from a member of the GGF's Fire Resistant Glazing Group.

[Section 9](#)

Appendix A - Membership of the Fire-Resistant Glazing Group

Fire Resistant-Glazing Group (FRGG)

Details of GGF members of the FRGG can be obtained from:

Glass and Glazing Federation,
54 Ayres Street,
London,
SE1 1EU

Tel: 0207 - 939 - 9100

Fax: 0207 - 357 - 7458

Email: info@ggf.org.uk

Website: www.ggf.org.uk

Visit our website for details of manufacturers, suppliers and installers of fire-resistant glass

FRGG Member who have assisted with the revision of this Best Practice Guide.

C3S Securiglass Ltd
Chiltern International Fire Ltd
Hodgson Sealants Ltd
Pilkington UK Ltd
Mann McGowan Fabrications Ltd
Schott UK Ltd
Sealmaster Ltd
Exova Warringtonfire

Appendix B—Summary of Impact Safety Requirements

Building Regulations:

England and Wales - Approved Document N

Scotland - Part 4.8 Building Standards

Northern Ireland - Technical booklet V

The following requirements must also be considered

Workplace health, safety and welfare. Workplace (Health, Safety and Welfare) Regulations 1992.

The consumer protection Act 2009

The General Product Safety Regulations 2005

The current Building Regulation requirements, in Approved Documents N and V refer to the use of impact safety products in hazardous locations, as illustrated in Figure B1.

Glazing should comply to BS 6262-4, this standard has been revised to take account of the following changes:

- Publication of harmonised European standards (hENs) for glass products;
- Withdrawal of BS 6206[1] for the classification of 'safety glass'; and
- The publication of BS EN 12600 for the classification of the pendulum impact performance of flat glass.

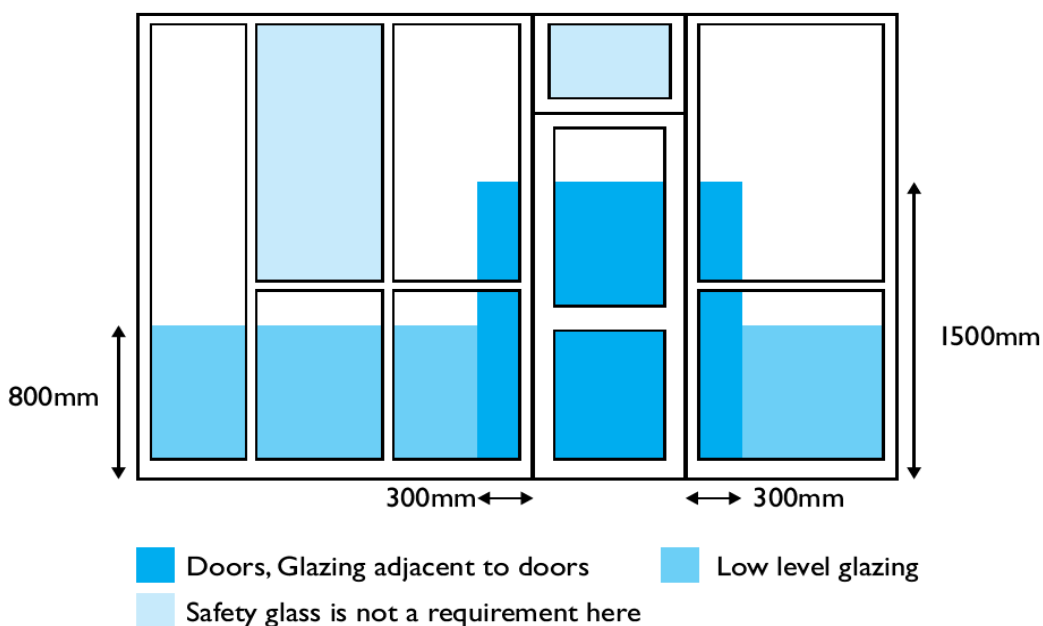

Key	
Doors and side panels over 900mm	Not less than BS 6262 Class 2
Doors and side panels up to 900mm	Not less than BS 6262 Class 3
Low level glazing	Generally to BS 6262 Class 3

Note: Areas of glass less than 0.5m² or less and a minor dimension of 250mm or less, may be glazed with annealed glass with a minimum thickness of 6mm except in the case of traditional leaded lights or copper lights.

Appendix B—Summary of Impact Safety Requirements

Table B1—Glass classification in accordance with BS EN 12600

Location	Pane Dimension	Glass Classification BS EN 12600
Door or door side panel	Minor dimension > 900mm	Class 2
	Minor dimension < 900mm	Class 3
	Minor dimension < 250mm with an area < 0.5m ²	No classification required. Minimum 6mm annealed, except lead and copper lights
Low level glazing	Minor dimension < 900mm	Class 3
	Minor dimension < 250mm with an area < 0.5m ²	No classification required. Minimum 6mm annealed, except lead and copper lights

Table B1 - Additional information on safety glazing can be found in the GGF publication “The right glazing in the right place”.

Other Building Regulations relating to glass

In some applications, fire-resistant glass may be required to provide guarding (see note 1).

For example, where it protects a difference in adjacent levels greater than 600mm in dwellings and 380mm in buildings other than dwellings, the glass should be designed as a barrier. Glass wholly or partially below the minimum barrier height should be in accordance with the recommendations in BS 6262-4 (see note 2) and be designed to satisfactorily withstand the given design loads:

- Horizontal uniformly distributed line load (often referred to as line load), applied at the design level, usually 1100mm from finished floor level
- Uniformly distributed load, applied to the infill (often referred to as infill UDL)
- Point (or concentrated) load, applied to part of the infill

(Table 1 of BS 6180 Table 1 gives minimum barrier heights)

Guidance on the suitability of a particular fire-resistant glass as a barrier should be obtained from the manufacturer or supplier (see note 3). Installing an appropriate handrail at 1100mm from finished floor level may not necessarily be sufficient to avoid the application of all of the barrier loads to the glass.

Notes

Note 1: Guarding is covered by the Building Regulations and the appropriate technical documents in England and Wales (Approved Document K), Scotland (Domestic and Non-domestic Technical Handbook Section 4) and Northern Ireland (Technical Booklet H).

Note 2: Protection against impact is covered by the Building Regulations and the appropriate technical documents in England and Wales (Approved Document N), Scotland(Domestic and Non-domestic Technical Handbook Section 4) and Northern Ireland(Technical Booklet V).

Note 3: The maximum areas for fully framed single glass panes can be found in Table 2 of BS 6180.

Appendix C - Requirements of Glazing Manifestation

If there is a risk that people could come into contact with large, uninterrupted areas of transparent glazing whilst moving in and about a building, paragraph N2 of the Building Regulations part N requires that such areas must incorporate features which make the glazing apparent.

This is called manifestation, and it may take the form of patterns, company logos, broken or solid lines, etc marked on the glass at appropriately defined heights and intervals.

In Part M of the Building Regulations, manifestation on glass is required at two heights:

- 850mm to 1000mm and 1400mm to 1600mm above floor level

Manifestation must contrast visually with the background seen through the glass, in both directions in all lighting conditions. It may take the form of a logo at least 150mm high, or a decorative feature, such as broken lines or continuous bands at least 50mm high. Glazed entrance doors that are adjacent to, or part of, a glazed screen, are clearly differentiated from the screen by a high contrast strip at the top and both sides.

Manifestation applies especially to defined critical locations, such as internal or external walls of shops, showrooms, offices, factories, public or other non-domestic buildings where there are likely to be groups, or moving streams, of people in the vicinity of the glazing.

Examples of door height glazing not warranting manifestation

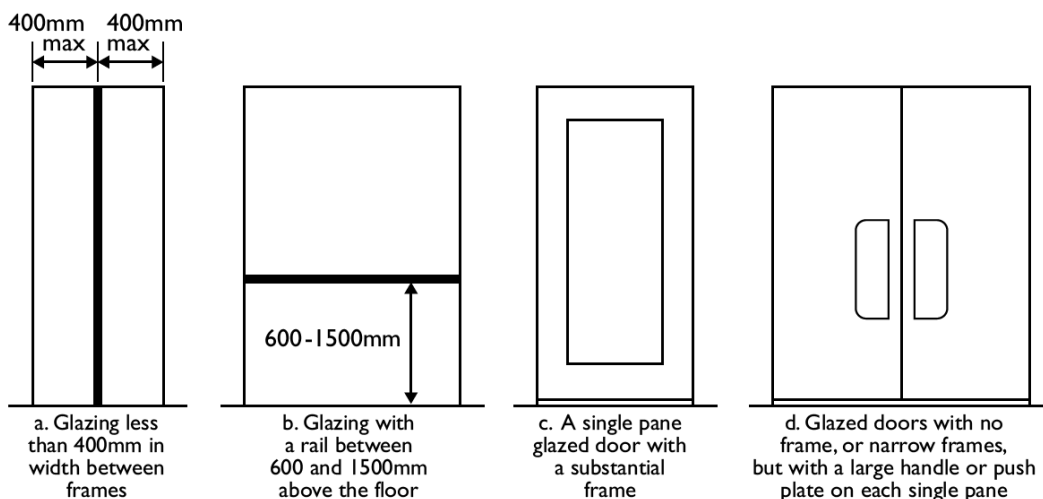

Appendix D - Contact details of Associated Organisations

Architectural and Specialist Door Manufacturers Association (ASDMA)

Burnside House,
3 Coates Lane,
High Wycombe,
Buckinghamshire
HP13 5EY

Tel: 01494 447370
Fax: 01494 462094

E-mail: info@asdma.com
www.asdma.com

Association of Interior Specialists (AIS)

Olton Bridge,
245 Warwick Road,
Solihull,
West Midlands
B92 7AH

Tel: 0121 707 0077
Fax: 0121 706 1949

E-mail: info@ais-interiors.org.uk
www.ais-interiors.org.uk

A British Woodworking Federation (BWF)

55 Tufton Street,
London
SW1 3QL

Tel: 0870 458 6939
Fax: 0870 458 6949

E-mail: bwf@bwf.org.uk
www.bwf.org.uk

Passive Fire Protection Federation (PFPF)

Association House,
99 West Street,
Farnham,
Surrey
GU9 7EN

Tel: 01252 739152
Fax: 01252 739140

E-mail: pfpf@associationhouse.org.uk
www.pfpf.org.uk

The Guild of Architectural Ironmongers

8 Stepney Green,
London
E1 3JU

Tel: 0207 790 3431
Fax: 0207 790 8517

E-mail: info@gai.org.uk
www.gai.org.uk

Steel Window Association

The Building Centre,
26 Store Street,
London
WC1E 7BT

Tel: 0207 637 3571
Fax: 0207 637 3572

E-mail: info@steel-window-association.co.uk
www.steel-window-association.co.uk

Appendix D - Contact details of Associated Organisations

National Building Specification (NBS)

The Old Post Office,
St Nicholas Street,
Newcastle upon Tyne
NE1 1RH

Tel: 0845 456 9594
Fax: 0191 232 5714

E-mail: info@theNBS.com
www.thenbs.com

Council for Aluminium in Building (CAB)

Bank House,
Bond's Mill,
Stonehouse
Gloucestershire
GL10 3RF

Tel: 01453 828851
Fax 01453 828861

E-mail: enquiries@c-a-b.org.uk
www.c-a-b.org.uk

Intumescent Fire Seals Association (IFSA)

20 Park Street,
Princes Risborough,
Buckinghamshire
HP27 9AH

Tel: 01844 276928
Fax: 01844 274002

E-mail: admin@ifsa.org.uk
www.ifsa.org.uk

Door and Hardware Federation (DHF)

42 Heath Street,
Tamworth,
Staffordshire
B79 7JH

Tel: 01827 52337
Fax: 01827 310827

E-mail: info@dhf.org.uk
www.dhf.org.uk

Association of Interior Specialists (AIS)

Olton Bridge,
245 Warwick Road,
Solihull,
West Midlands,
B92 7AH

Tel: 0121 707 0077
Fax: 0121 7061949

E-mail: info@ais-interiors.org.uk
www.ais-interiors.org.uk

Disclaimer

This best practice guide is produced by the Glass and Glazing Federation (GGF) and is issued for guidance only. The GGF takes no responsibility for reliance on any advice given, for any omissions from the guide or for the consequences of users acting in accordance with contents of the guide. Whilst every attempt is made to present up-to-date information and accurate guidance, any liability on the part of the GGF arising in connection with this guide is expressly disclaimed.

Proprietary product names referred to in the guide are those produced or supplied by members of the Fire Resistant Glazing Group of the GGF. This is not to imply that products from non-members are unsuitable for use in fire-resistant glazed systems. Such products may be suitable, always conditional upon the availability of appropriate evidence of performance founded on relevant test information.



Glass and Glazing Federation

54 Ayres Street,
London, SE1 1EU

info@ggf.org.uk
www.ggf.org.uk

Price £25